

**HP 8960 Series 10 E5515A Wireless Communications Test Set
HP E1960A GSM Mobile Test Application**

HP-IB Command Syntax

<http://www.hp.com/hp8960support/>

Test Application Revision A.02

© Copyright Hewlett-Packard 1999

Printed in U.S.A. July 1999

HP Part Number: E1960-90003

Revision F



Notice

Information contained in this document is subject to change without notice.

All Rights Reserved. Reproduction, adaptation, or translation without prior written permission is prohibited, except as allowed under the copyright laws.

This material may be reproduced by or for the U.S. Government pursuant to the Copyright License under the clause at DFARS 52.227-7013 (APR 1988).

Hewlett-Packard Company
Learning Products Department
24001 E. Mission
Liberty Lake, WA 99019-9599
U.S.A.

Contents

Diagram Conventions	7
Diagram Description	8
Developing Code	8
ABORT	10
AFGenerator	11
CALibration	12
CALL:ACTivated	13
CALL:BA	14
CALL:BAND	15
CALL:BCCode	16
CALL:BCHannel	17
CALL:BURSt	18
CALL:CONNected	19
CALL:COUNT	20
CALL:END	21
CALL:FUNction	22
CALL:IMEI	23
CALL:LACode	24
CALL:MCCode	25
CALL:MNCode	26
CALL:MS	27
CALL:NCCode	30

Contents

CALL:OPERating	31
CALL:ORIGinate	32
CALL:PAGing	33
CALL:PMNCode	34
CALL:POWer	35
CALL:RFGenerator	36
CALL:STATus	39
CALL:TCHannel	40
DISPlay	44
FETCh:AAUDio	45
FETCh:BErRor	46
FETCh:DAUDio	48
FETCh:FBERror	49
FETCh:ORFSpectrum	50
FETCh:PFERror	52
FETCh:PVTime	54
FETCh:TXPower	57
INITiate	58
READ	60
RFANalyzer	61
SETup:AAUDio	63
SETup:BErRor	65

Contents

SETup:CONTInuous	67
SETup:DAUDio	68
SETup:FBError	70
SETup:ORFSpectrum	72
SETup:PFError	76
SETup:PVTime	78
SETup:TXPower	80
STATus:OPERation	82
STATus:PRESet	85
STATus:QUEStionable	86
Status Byte Register	90
*STB?	90
Standard Event Status Register	91
*ESR?	91
*ESE?	91
*ESE	91
SYSTem:BEEPer	92
SYSTem:COMMunicate	93
SYSTem:CORRection	94
SYSTem:CURRent:TA	95
SYSTem:ERRor?	96
SYSTem:FTRigger	97

Contents

SYSTem:MEASurement	98
SYSTem:PRESet	99
SYSTem:ROSCillator	100
SYSTem:SYNChronized	101
HP-IB IEEE 488.2 Common Commands	102
*CLS	103
*ESE	103
*ESE?	103
*ESR?	104
*IDN?	104
*OPC	104
*OPC?	105
*OPT?	105
*RST	106
*SRE	107
*SRE?	107
*STB?	108
*WAI	108

Diagram Conventions

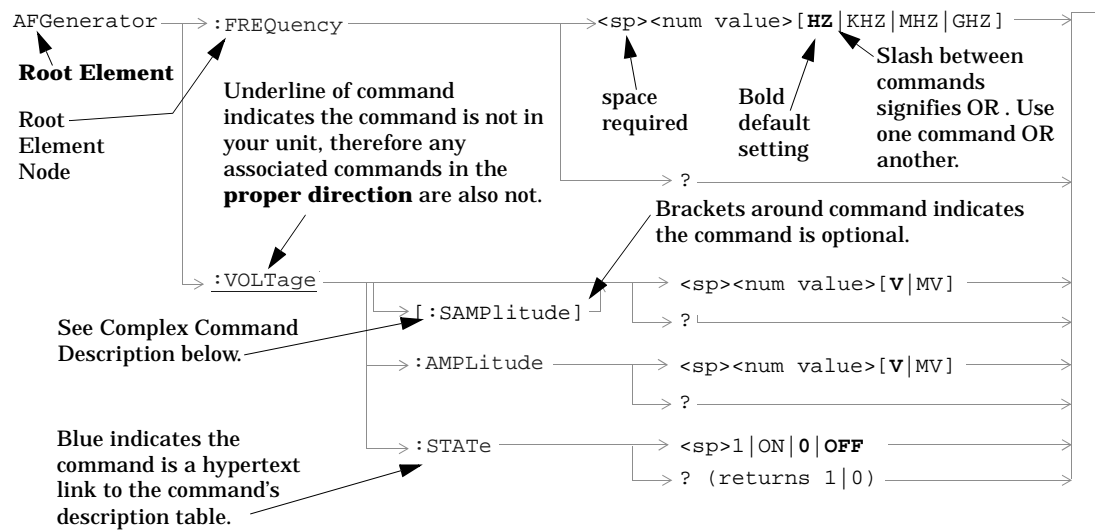

Diagram Description

Statement elements are connected by lines. Each line can be followed in only one direction, as indicated by the arrow at the end of the line. Any combination of statement elements that can be generated by starting at the **Root Element** and following the line the **proper direction** is syntactically correct. The drawings show the proper use of spaces. Where spaces are required they are indicated by <sp>, otherwise no spaces are allowed between statement elements.

Complex Command Description

A complex command sets the state of the parameter to ON, and is used to set a value for that parameter. These parameters; amplitude, frequency, gain, number, time, and value can be used as a complex command. Refer to the specific command for the parameter that applies.

Developing Code

It is recommended that you set the Test Set's operating environment to debug. To set the Test Set debug mode to "ON" use the following syntax:

```
SYSTem:COMMunicate:GPIB:DEBug ON
```

Units-of-Measure

If you do not specify units-of-measure in your code the following table indicates the default units-of-measure that will be assumed.

Amplitude (linear)	V
Frequency	HZ
Power (logarithmic)	dBm
Time	S

ABORT

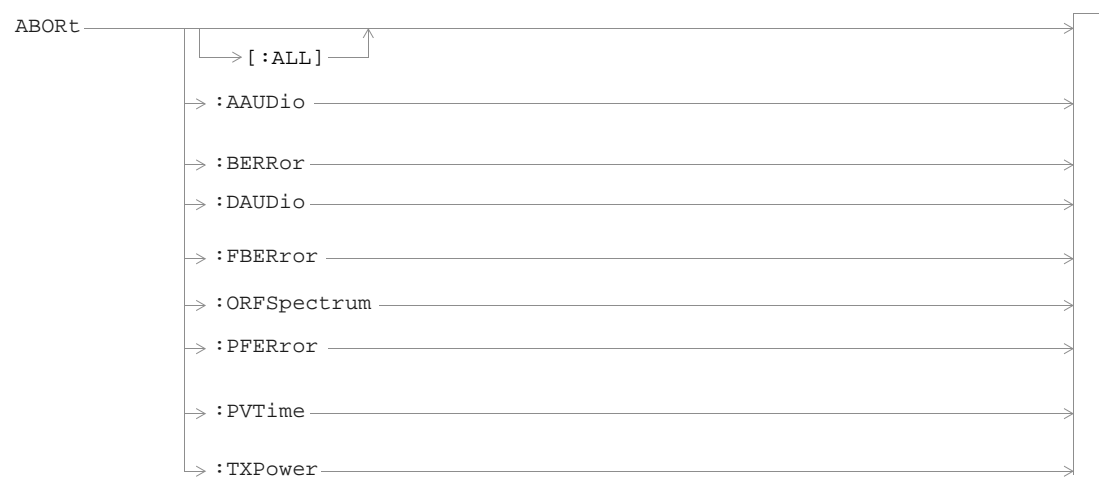

AFGenerator

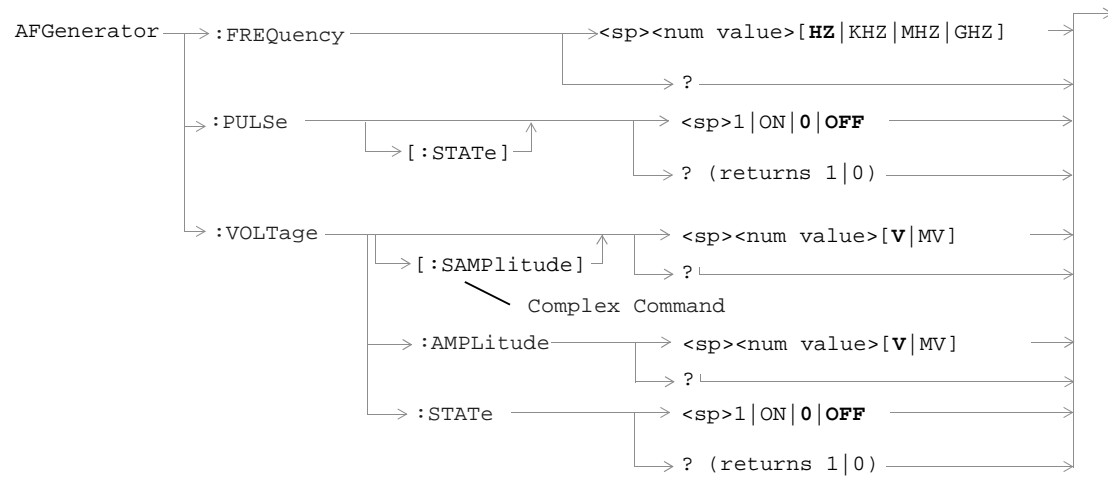

CALibration

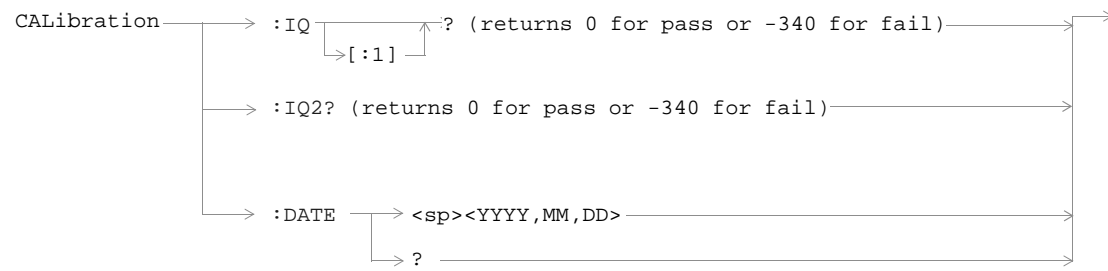

CALL:ACTivated

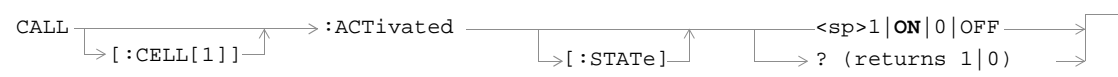

CALL:BA

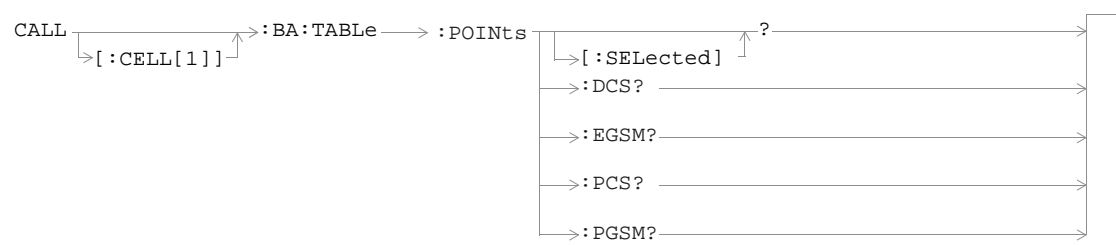
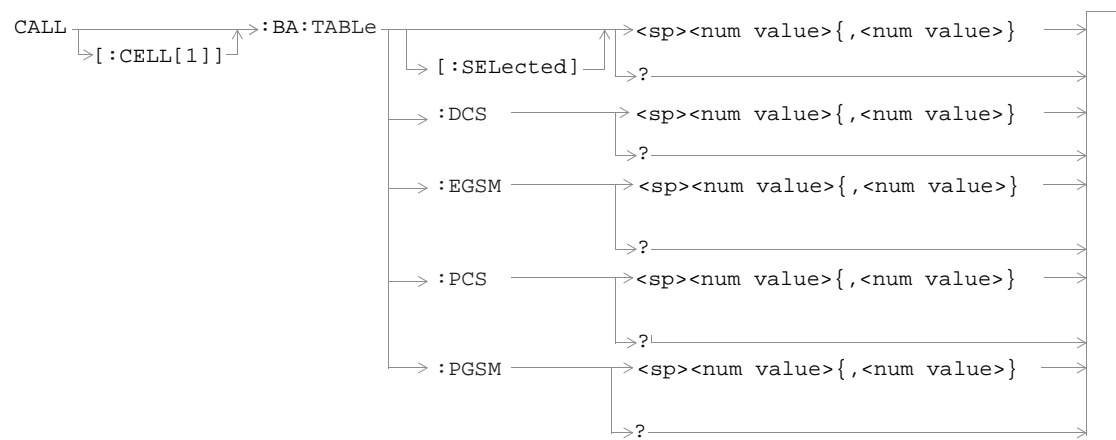

CALL:BAND

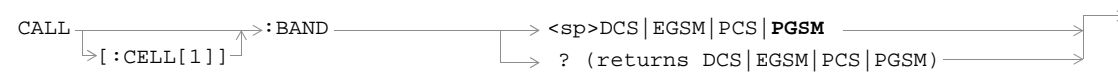

CALL:BCCode



CALL:BCHannel

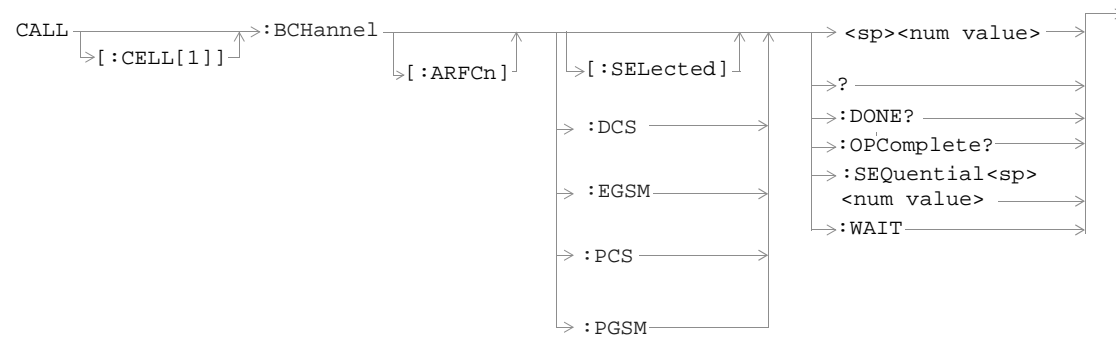

CALL:BURSt



CALL:CONNEcted

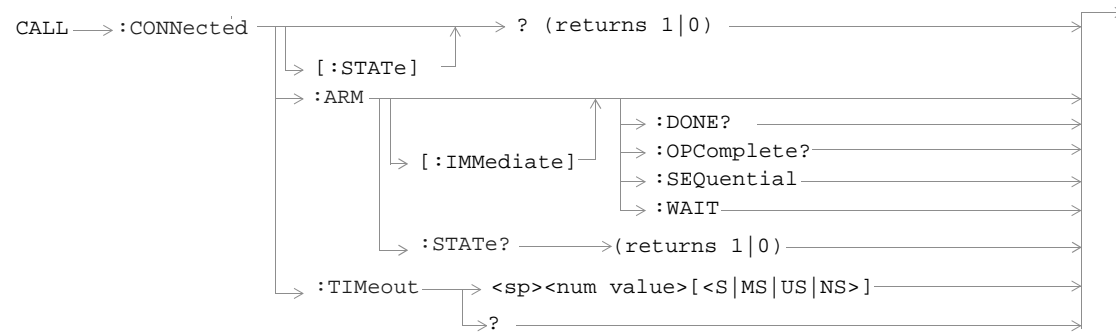

CALL:COUNT

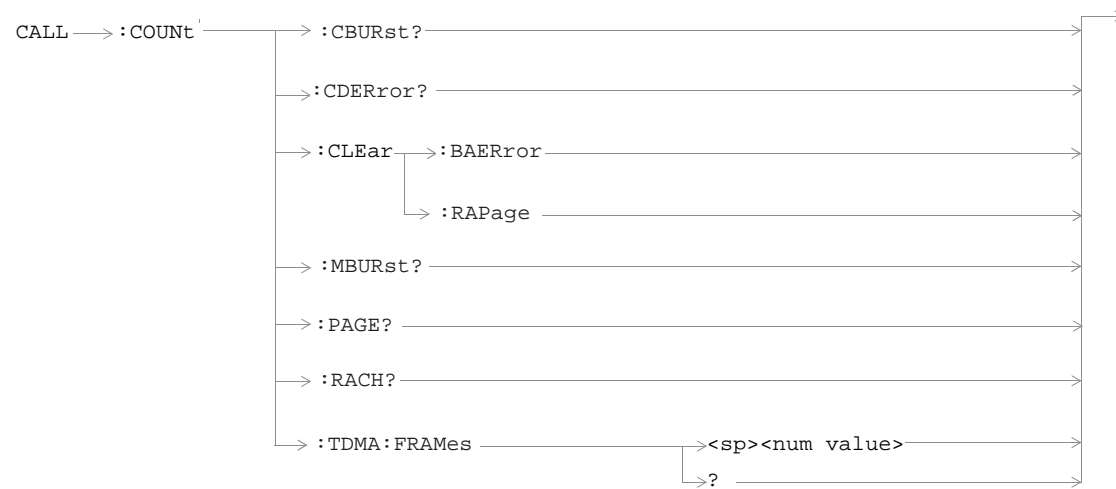

CALL:END

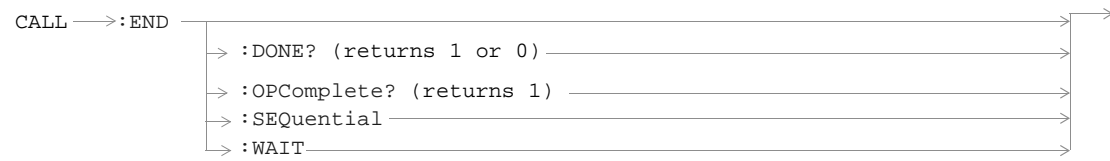

CALL:FUNCTION



CALL:IMEI

CALL → :IMEI:AUTO → <sp>1|ON|0|OFF →
? (returns 1|0) →

CALL:LACode

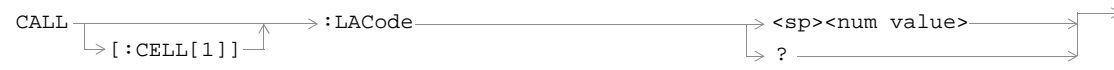

CALL:MCCode



CALL:MNCCode

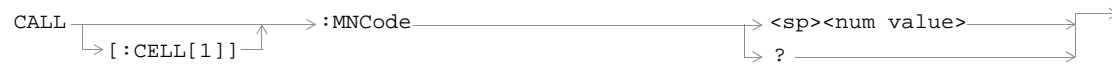

CALL:MS

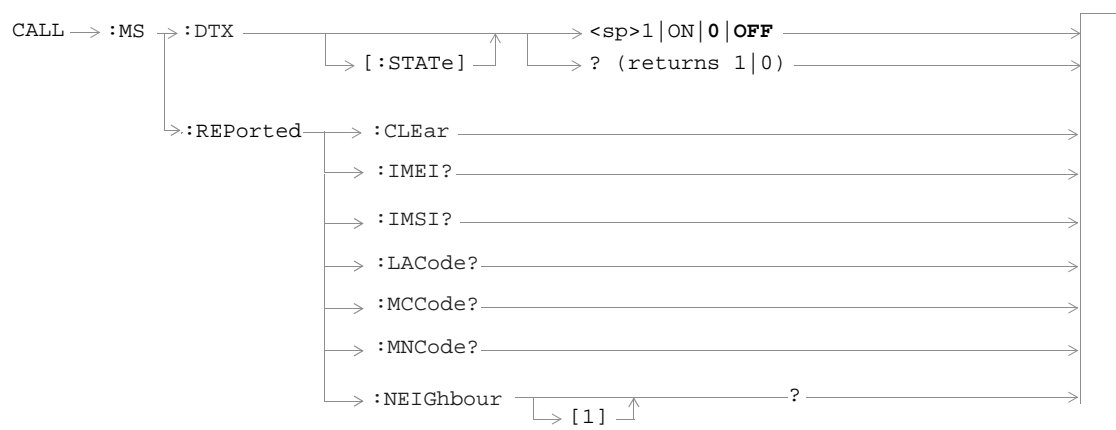

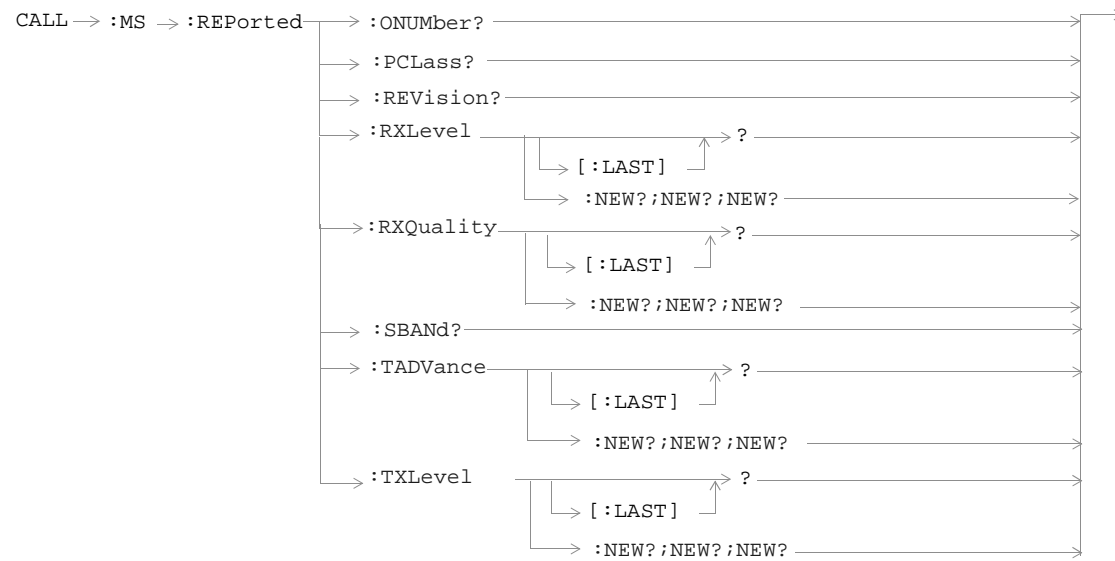

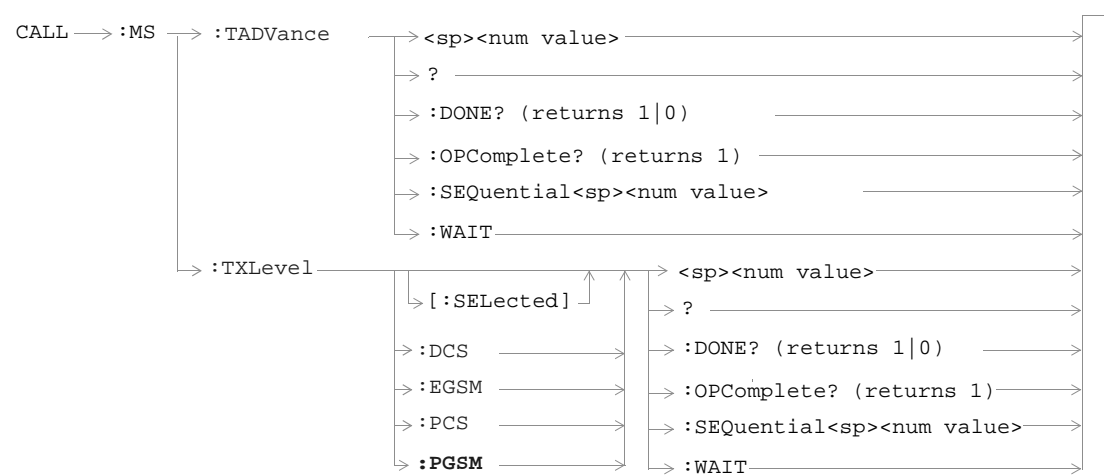

CALL:NCCode



CALL:OPERating

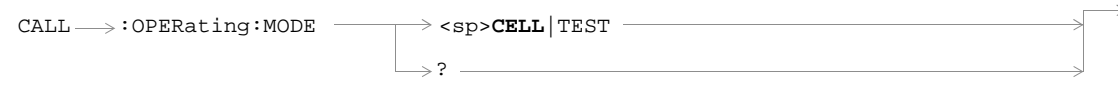

CALL:ORIGinate



CALL:PAGing

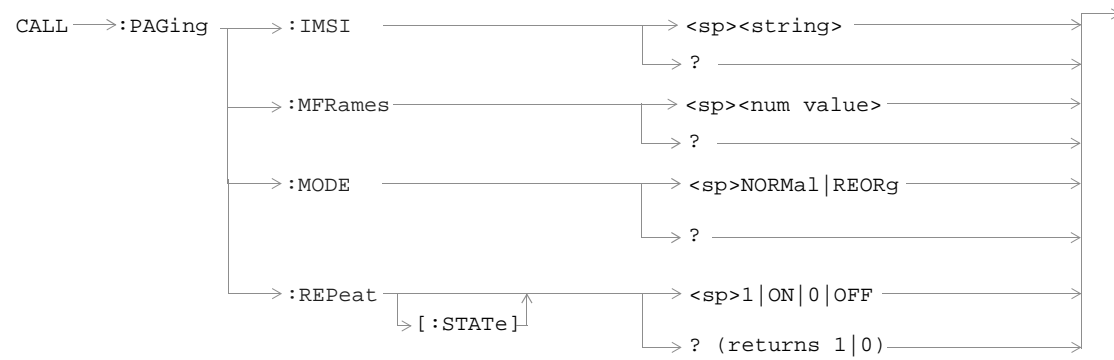

CALL:PMNCode

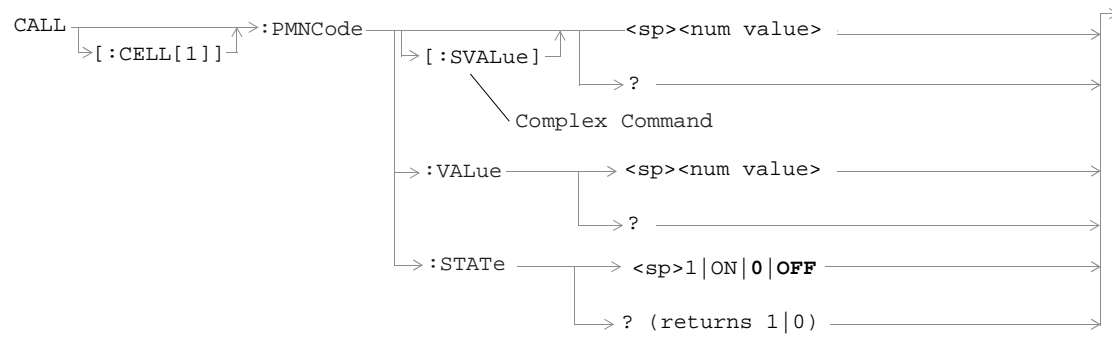

CALL:POWer

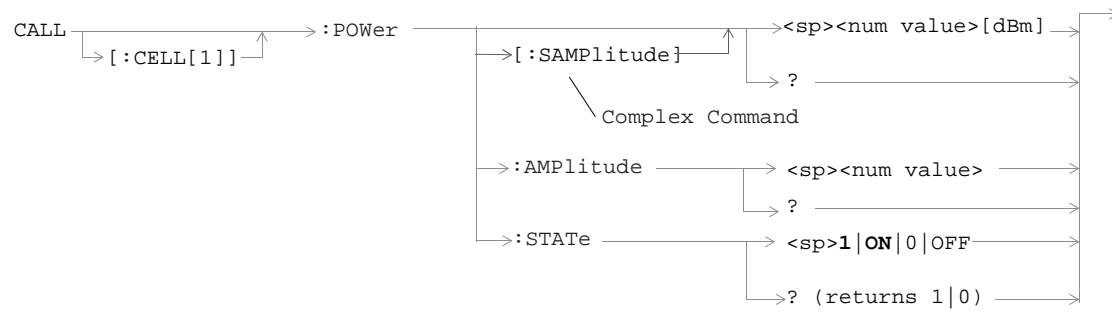

CALL:RFGenerator

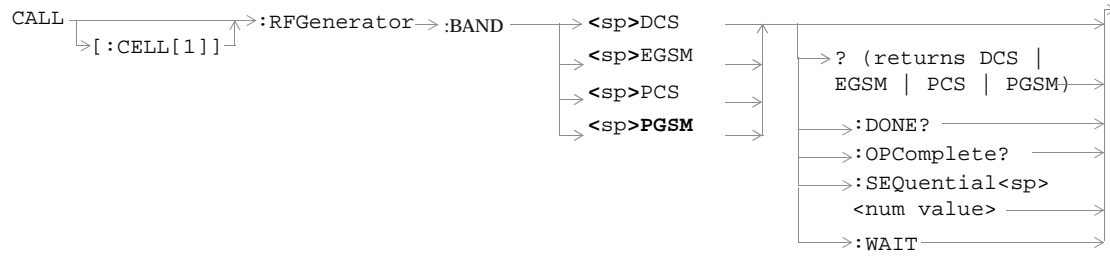

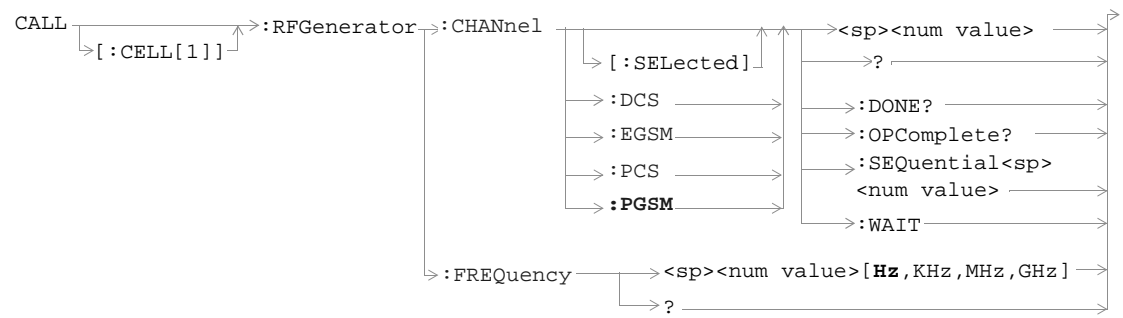

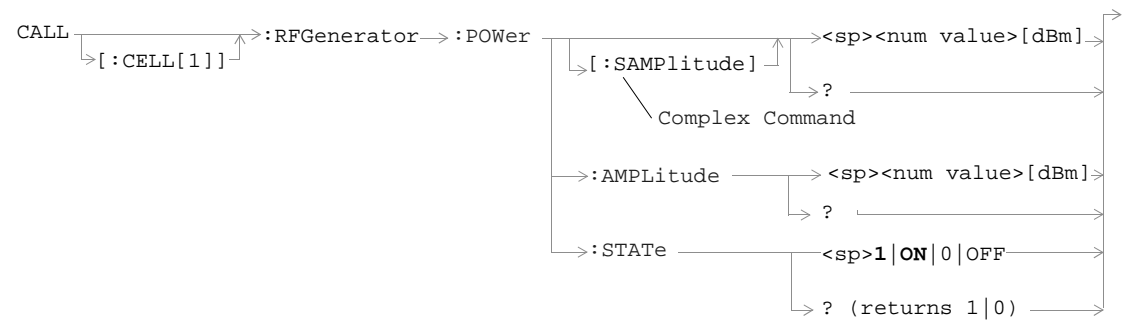

CALL:STATus

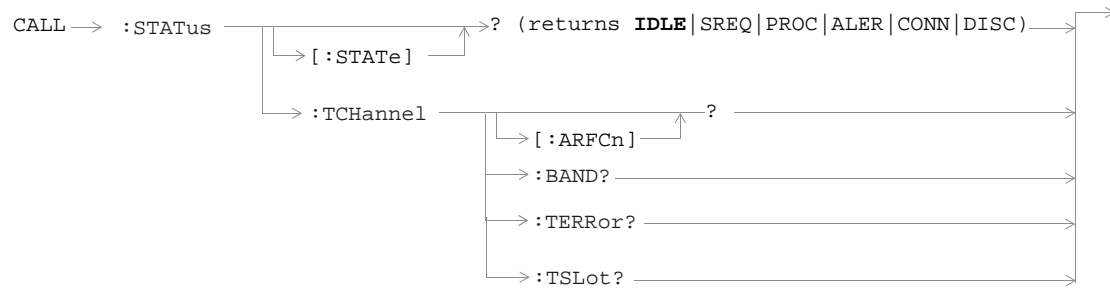

CALL:TCHannel

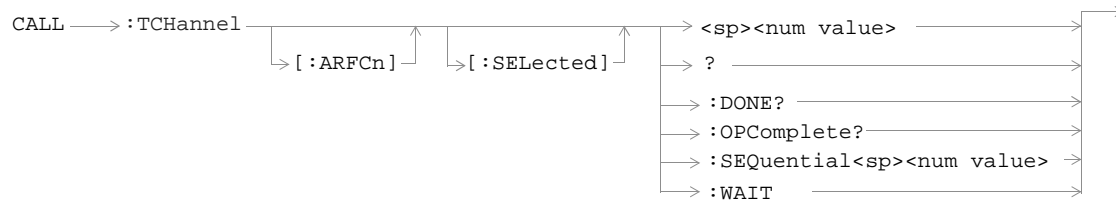

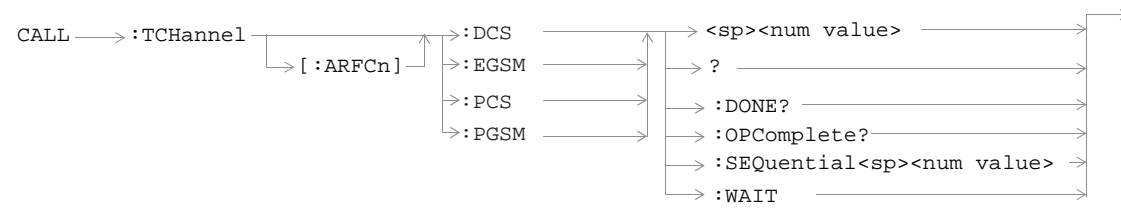

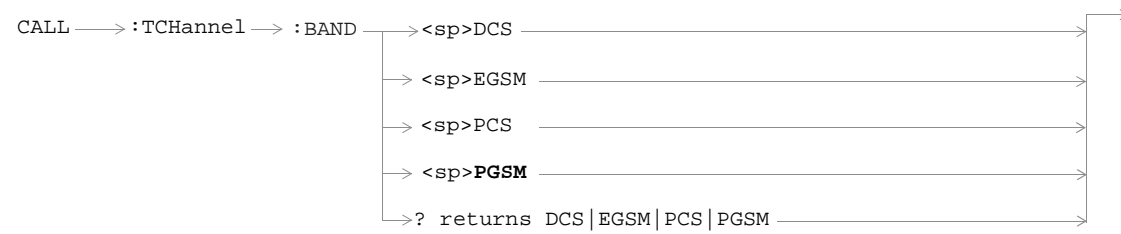

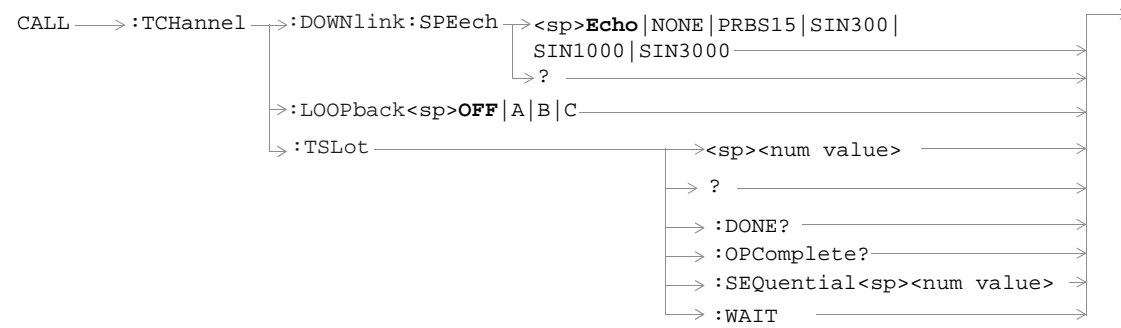

DISPlay

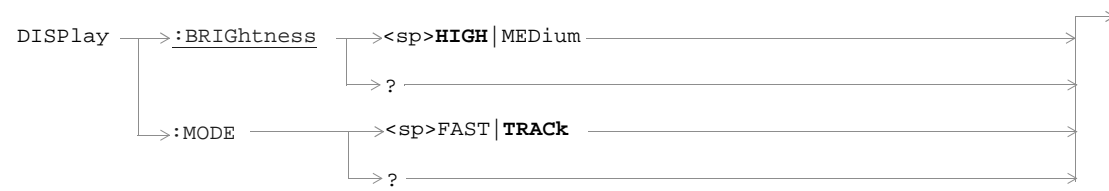

FETCh:AAudio

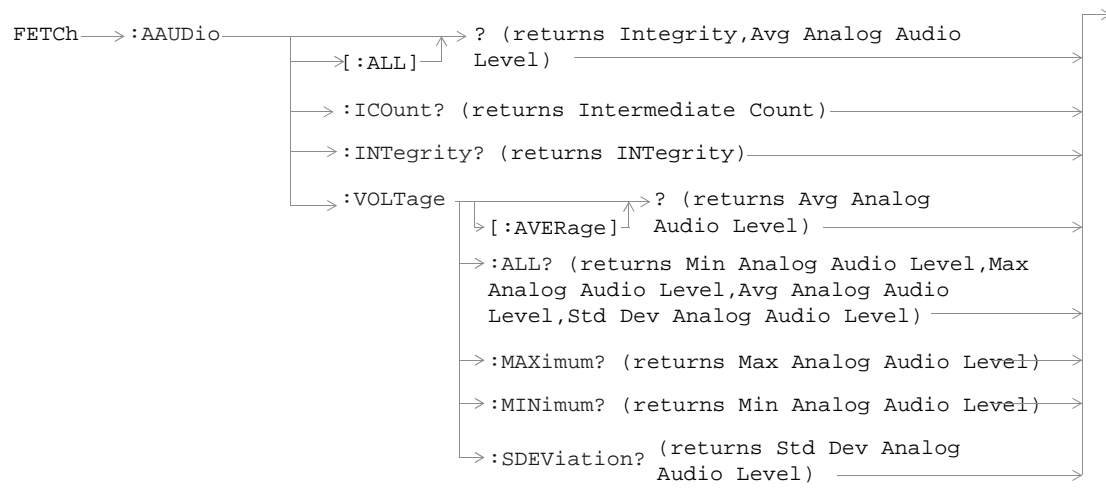

FEtCh:BErRor

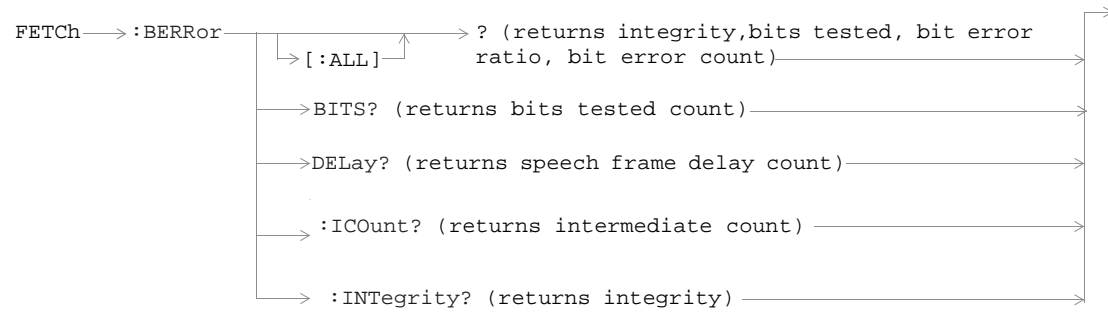

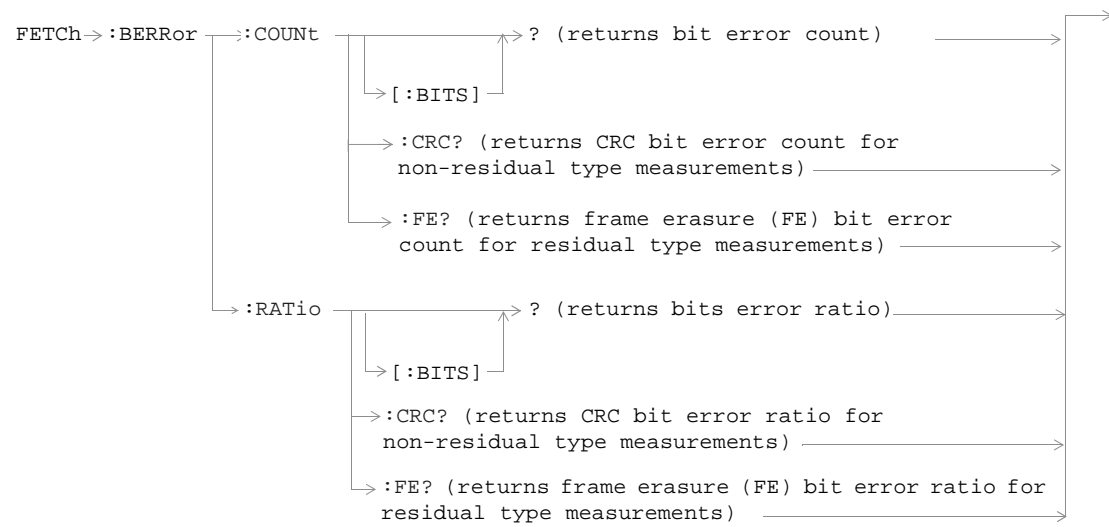

FETCh:DAUDio

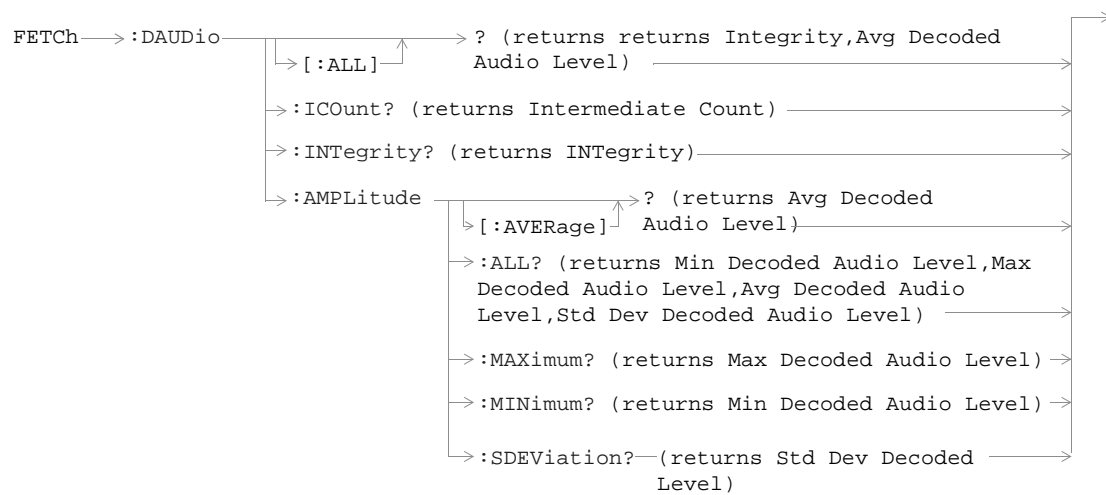

FETCH:FBERror

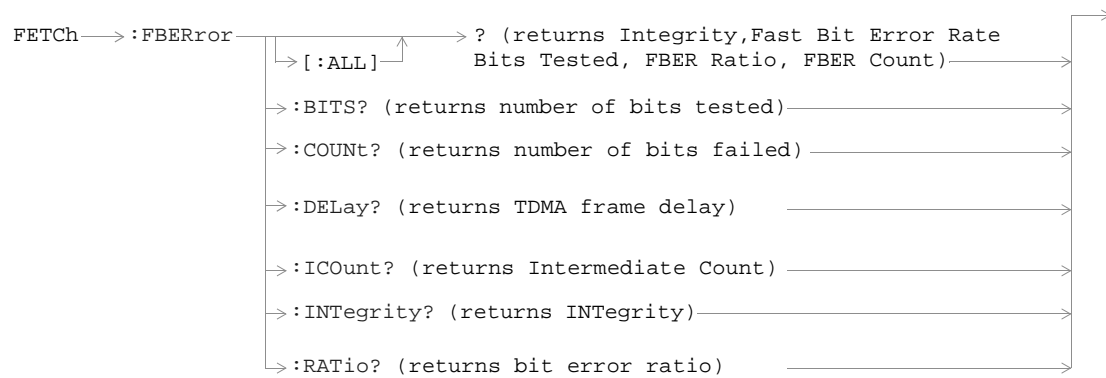

FETCH:ORFSpectrum

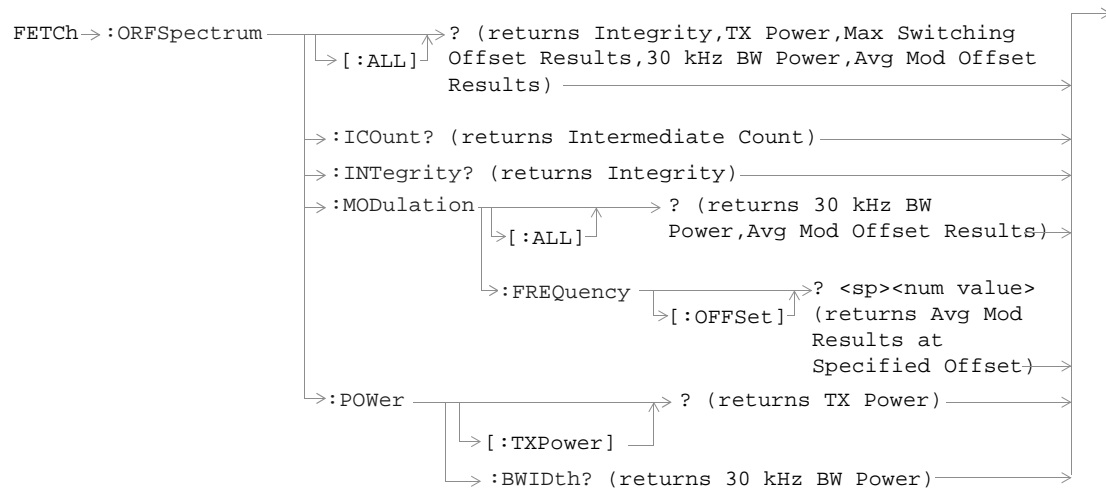

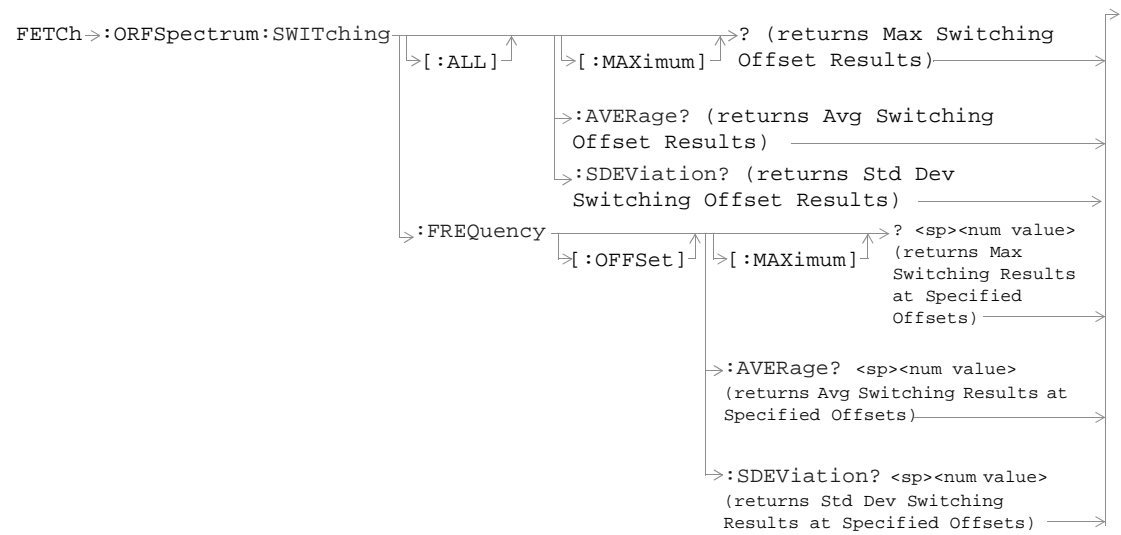

FETCh:PFERror

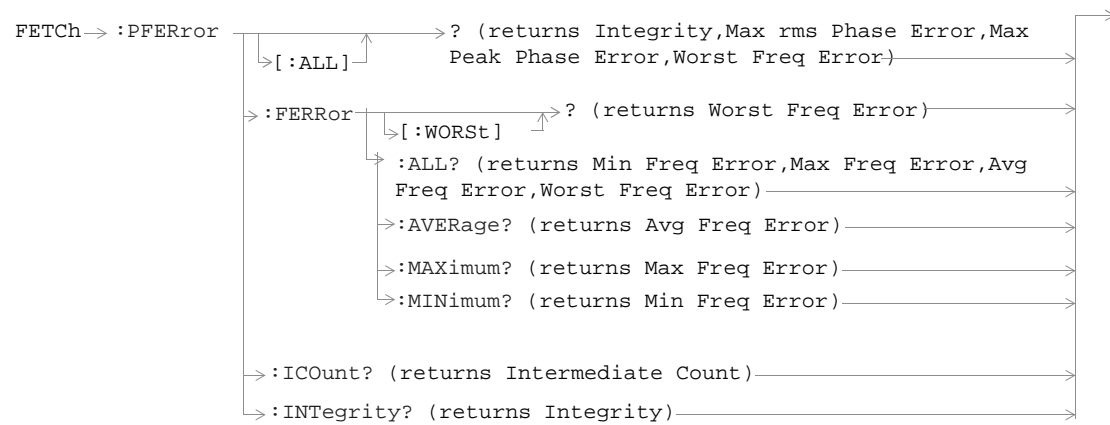

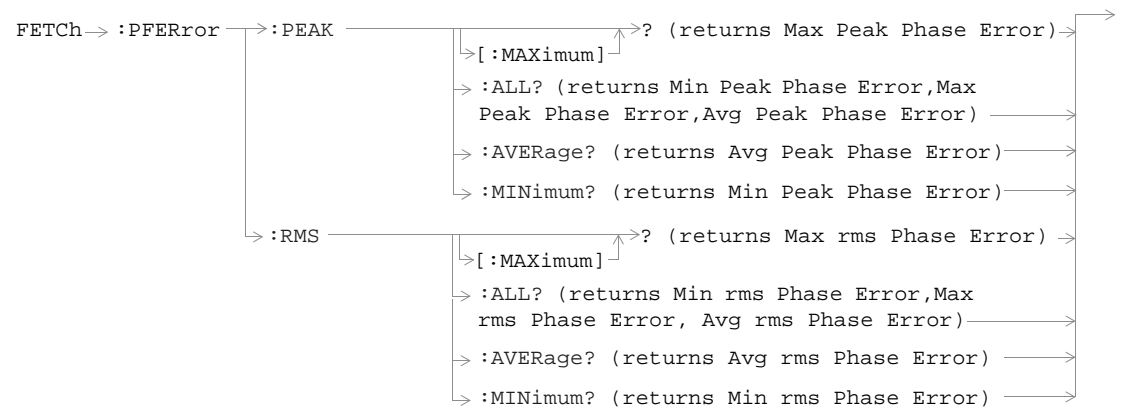

FETCh:PVTime

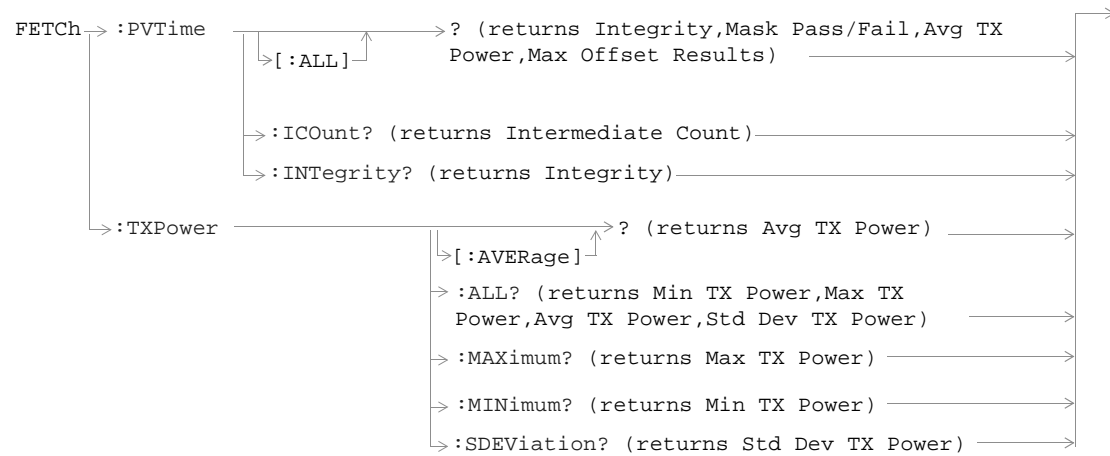

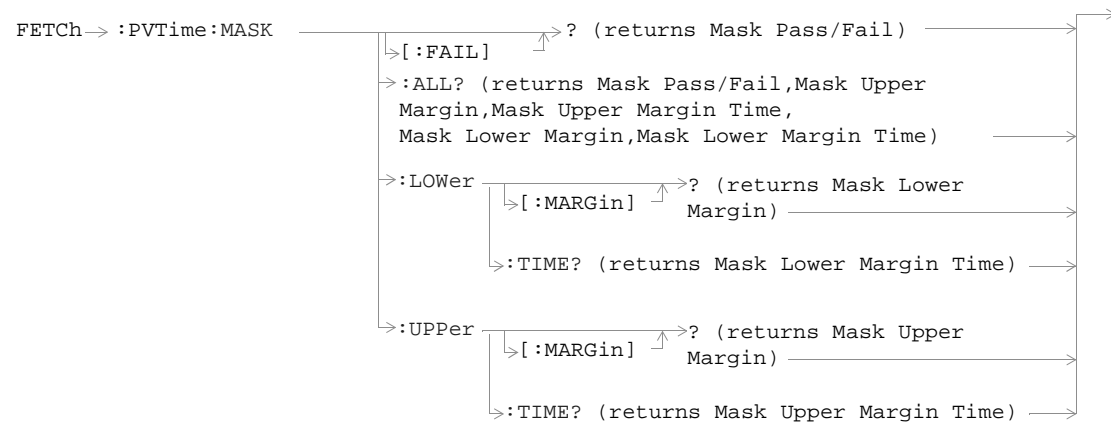

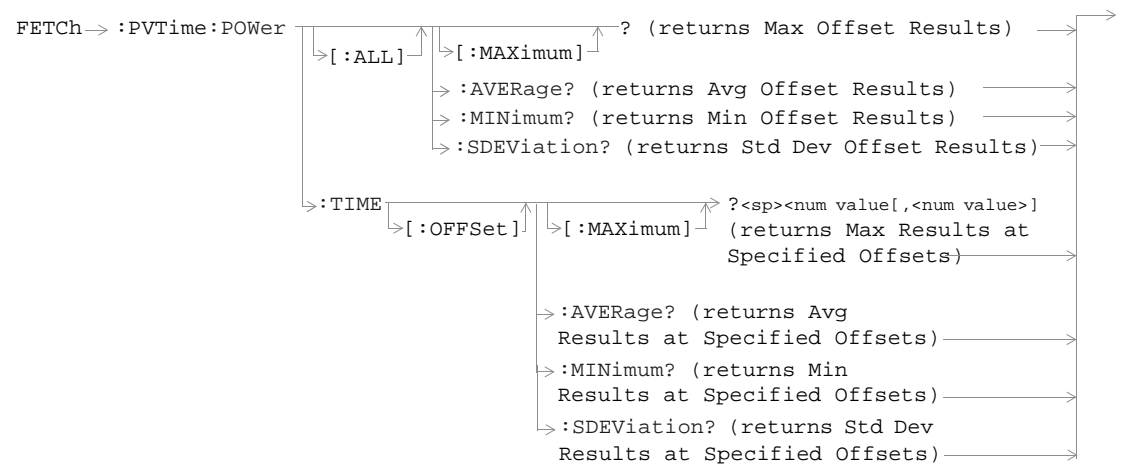

FETCh:TXPower

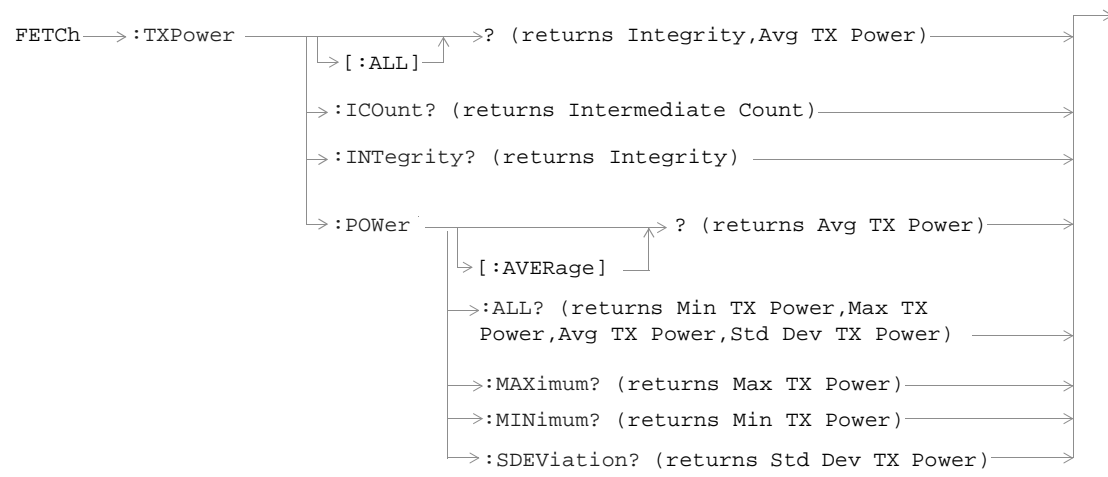

INITiate

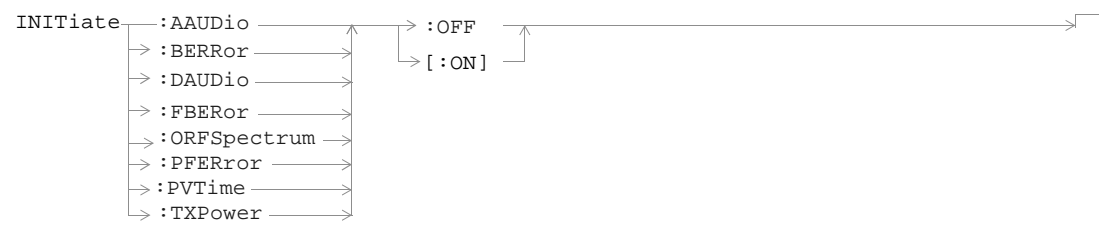

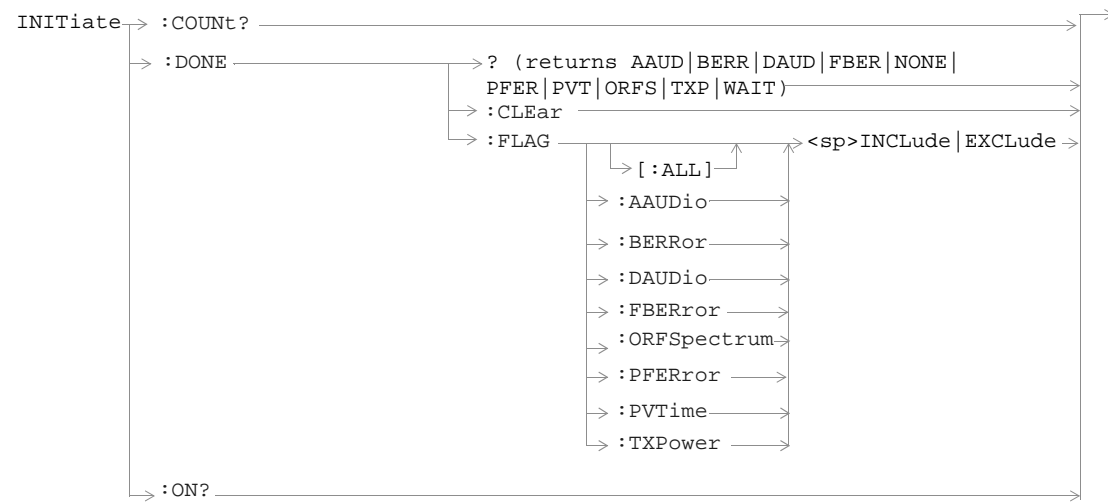

READ

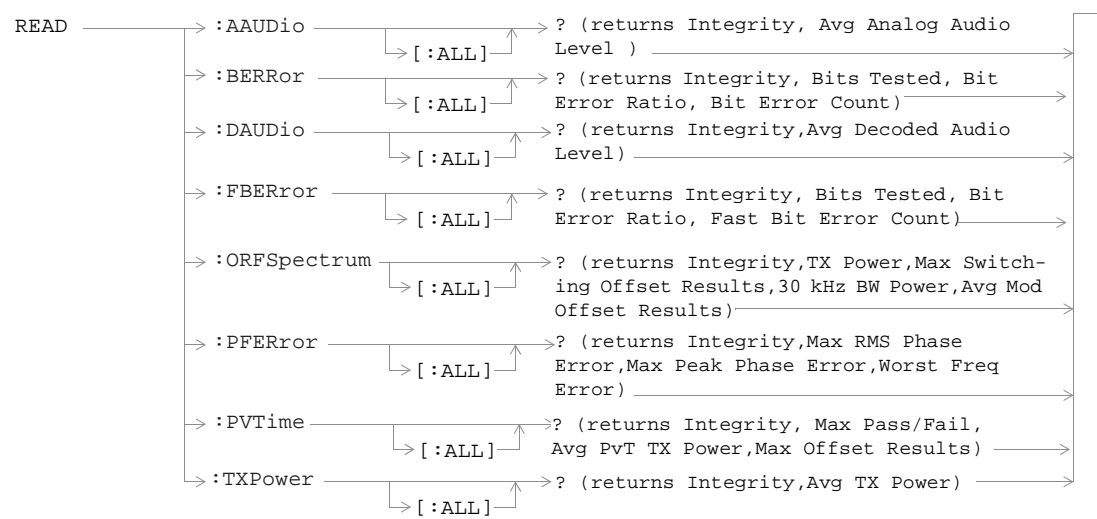

RFAnalyzer

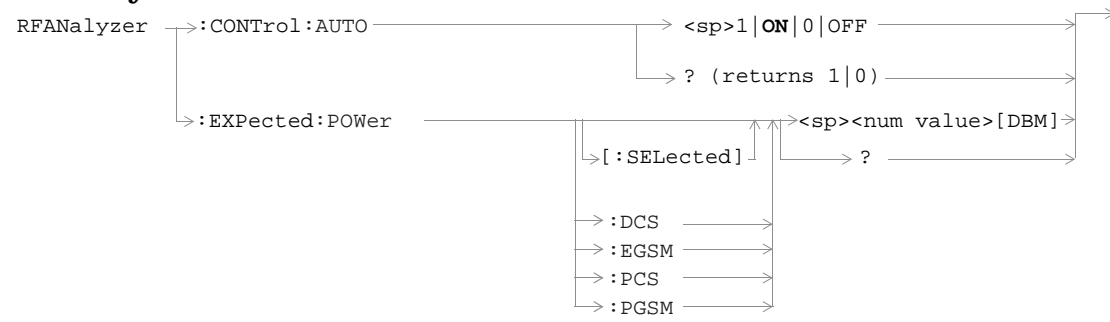

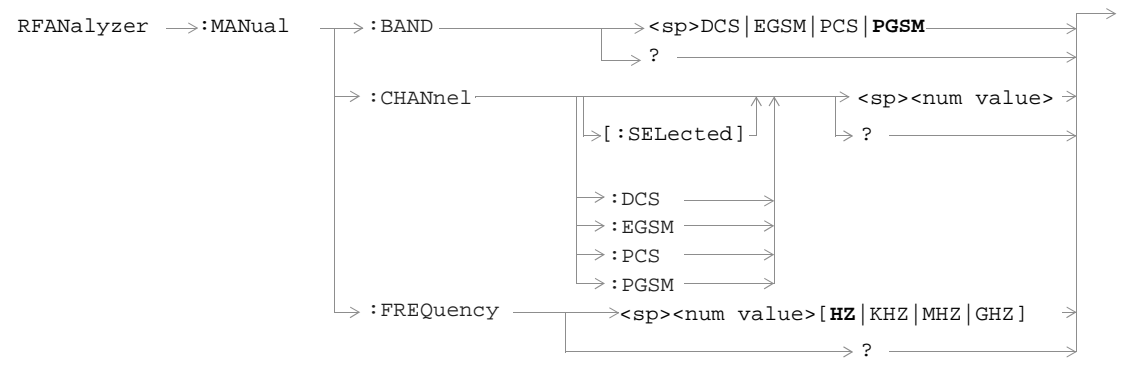

SETup:AAUDio

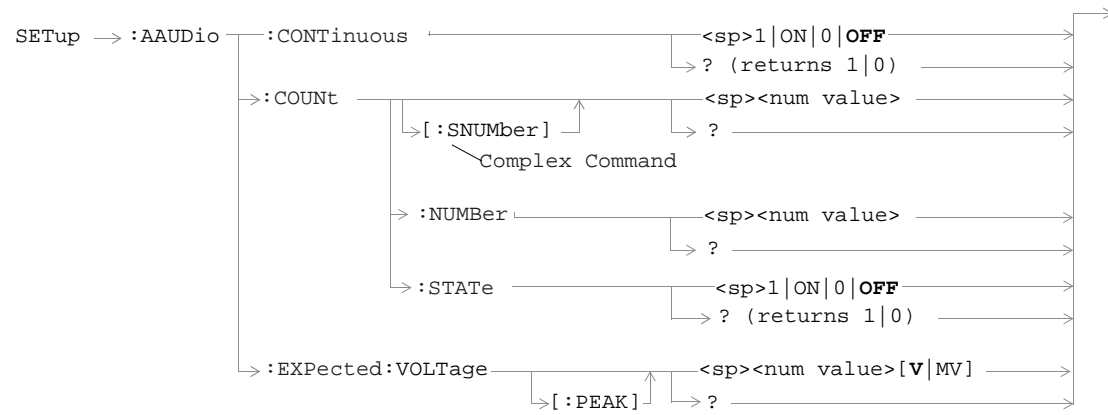

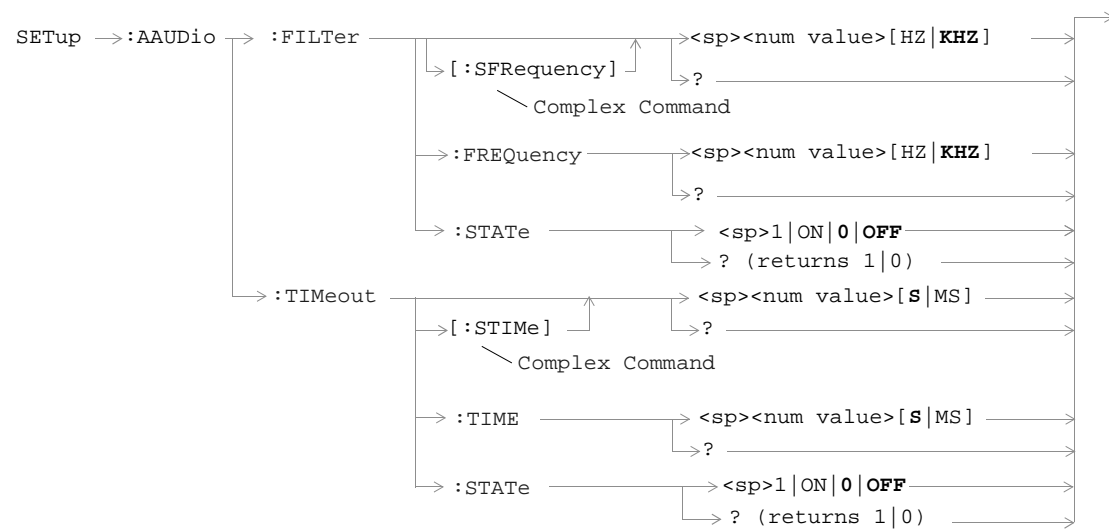

SETup:BERRor

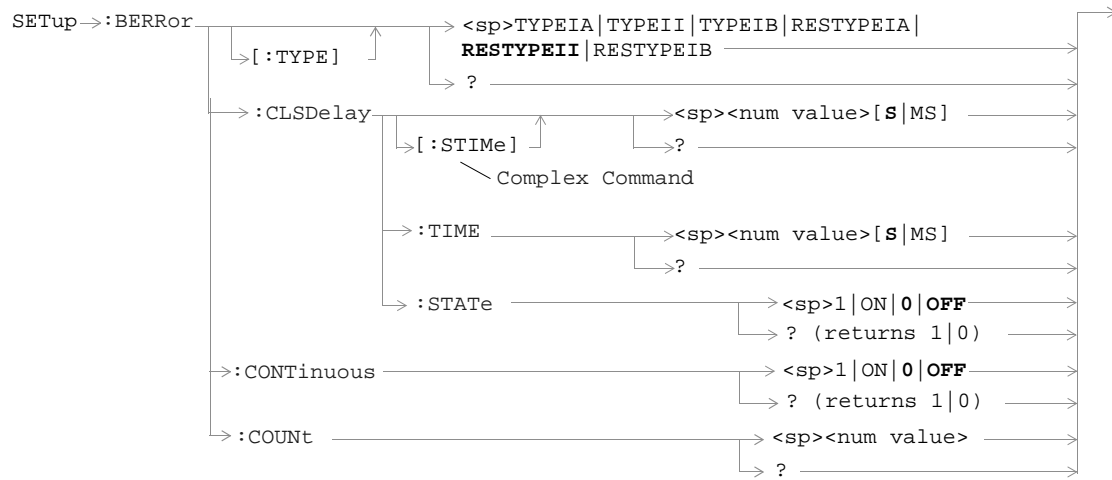

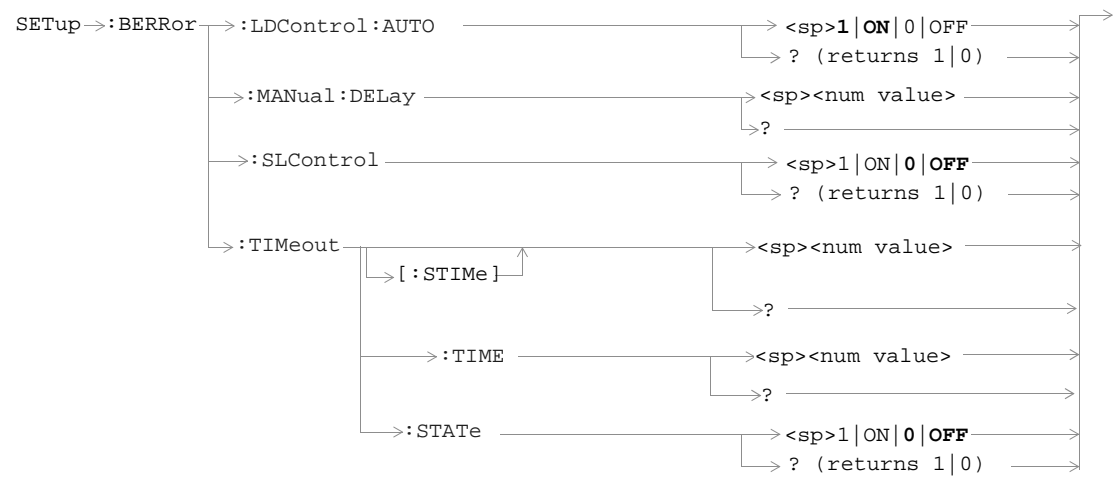

SETup:CONTInuous

SETup → :CONTInuous → :OFF | :ON →
└─> [:ALL] ┘

SETup:DAUDio

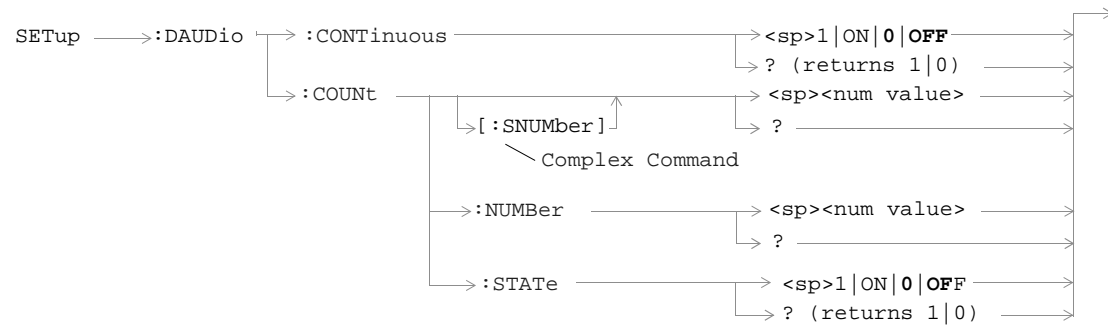

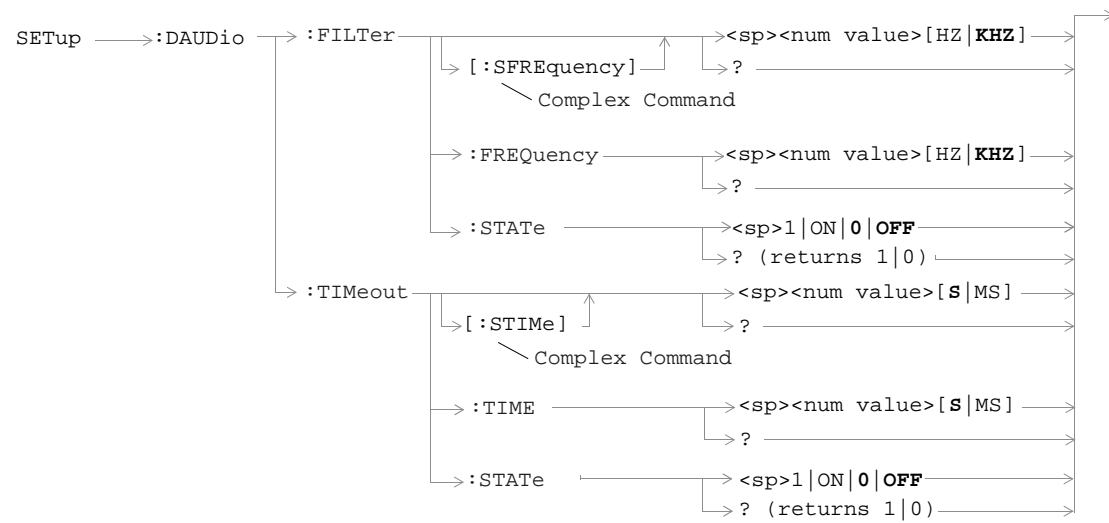

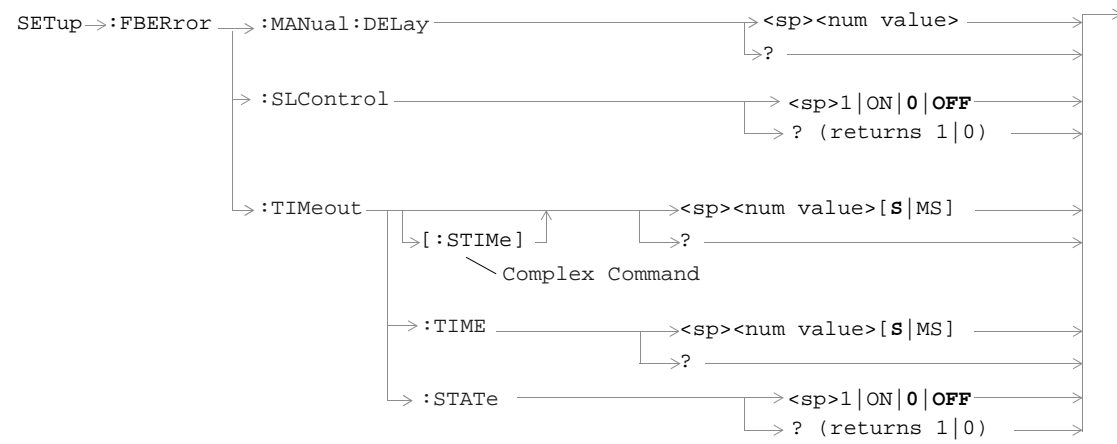

SETup:ORFSpectrum

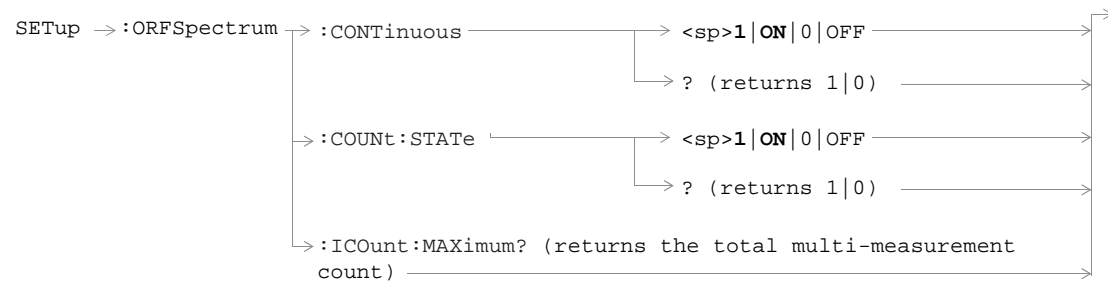

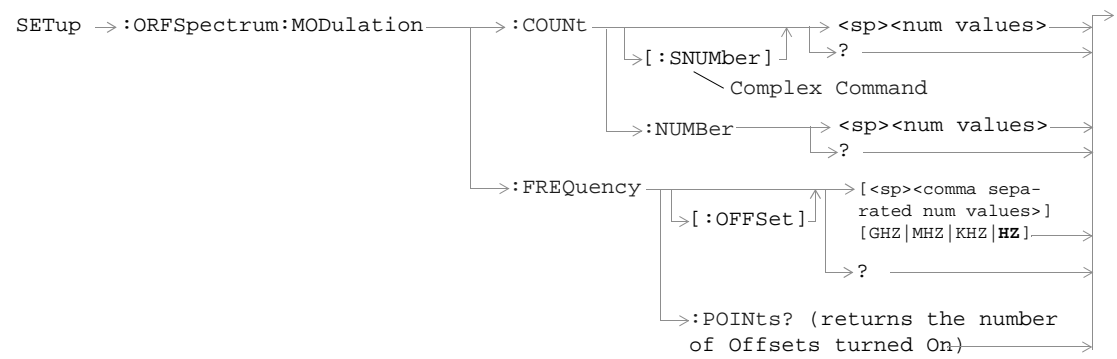

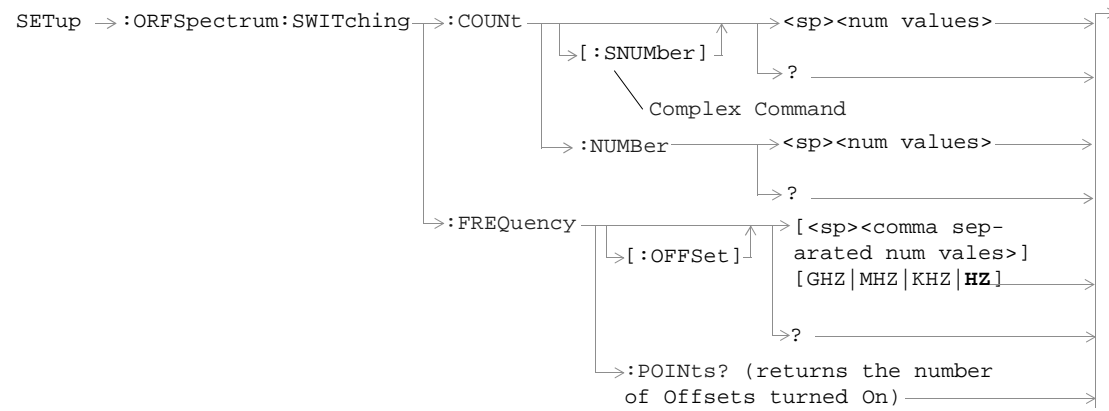

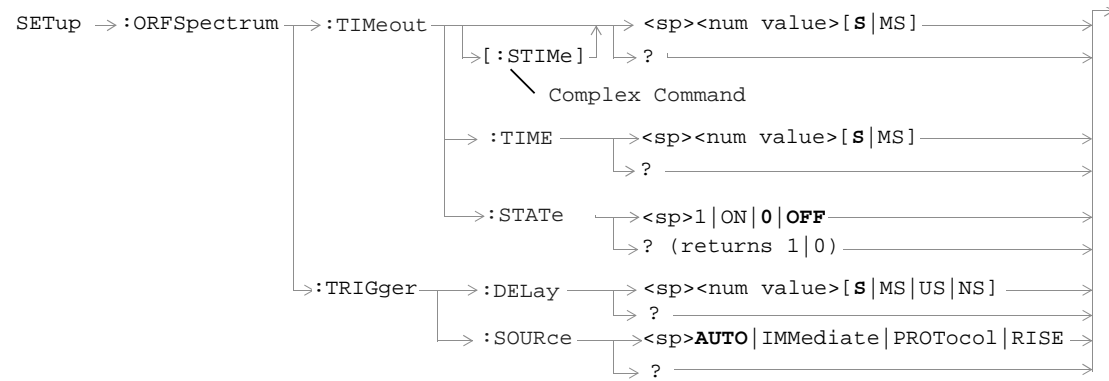

SETup:PFERror

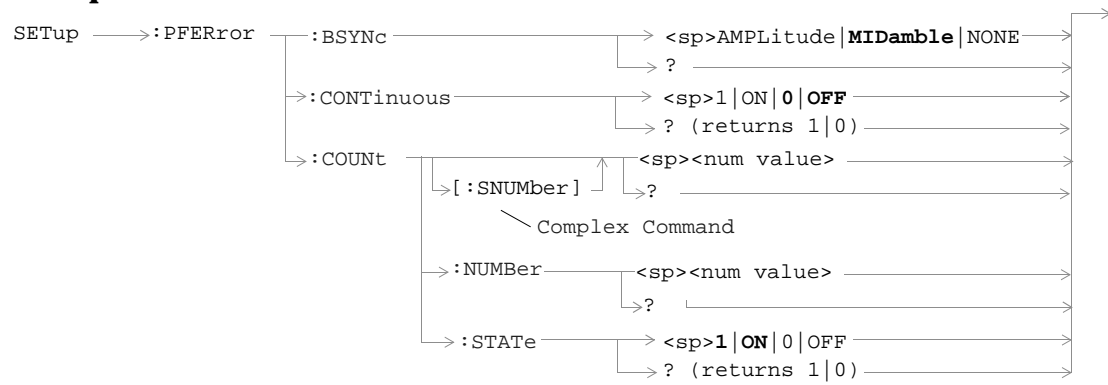

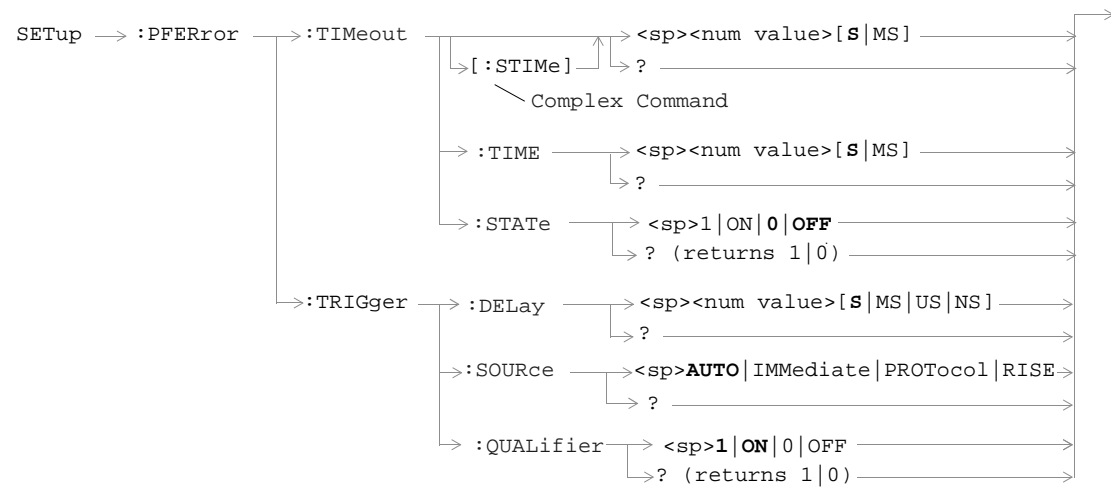

SETup:PVTime

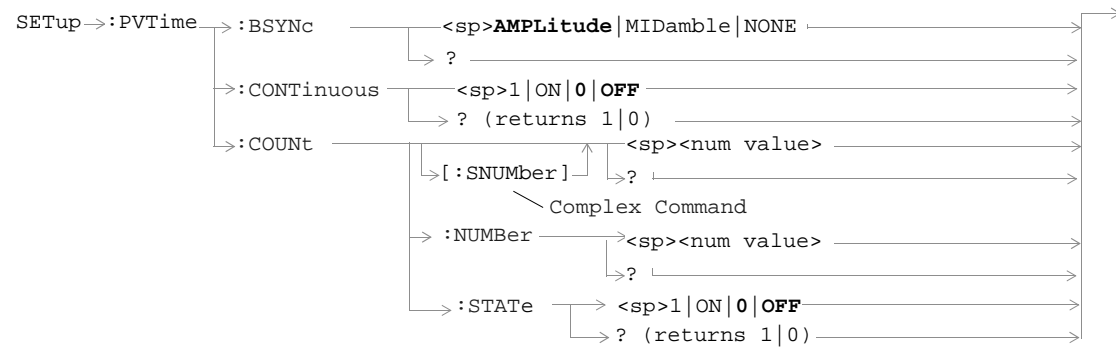

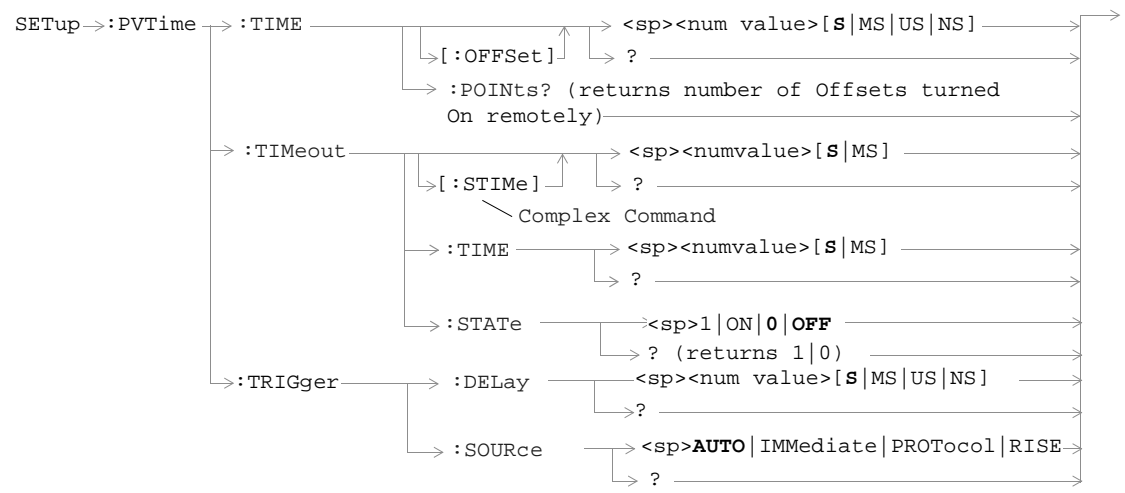

SETup:TXPower

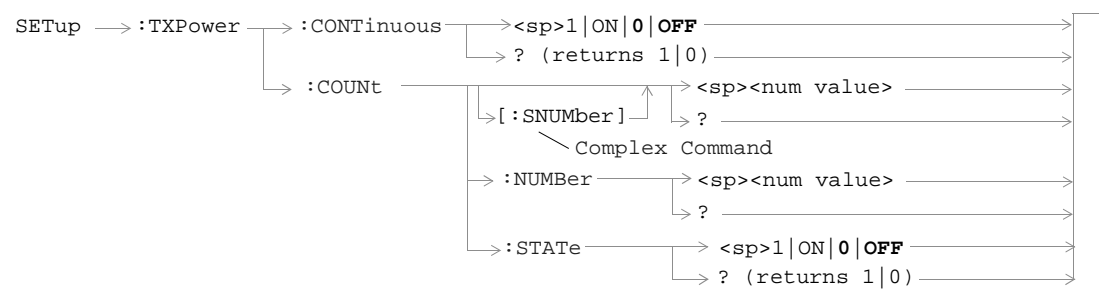

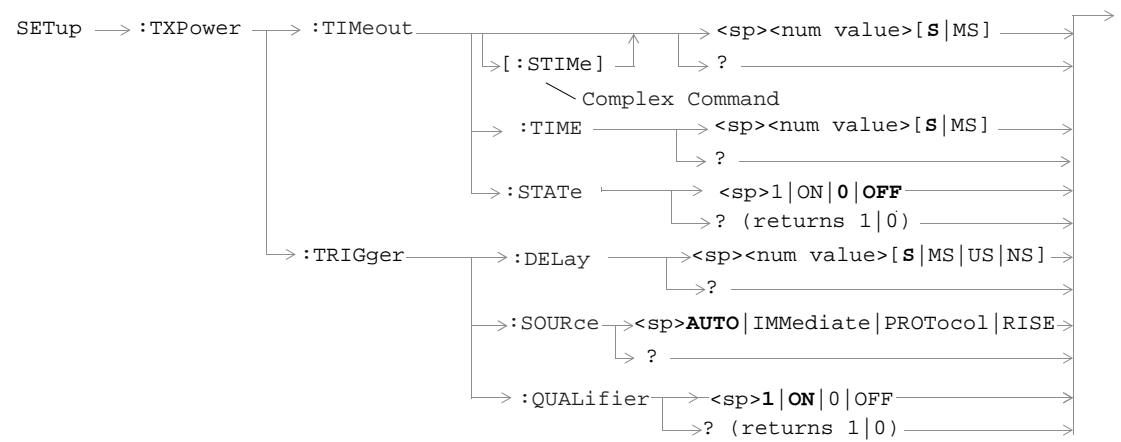

STATUS:OPERation

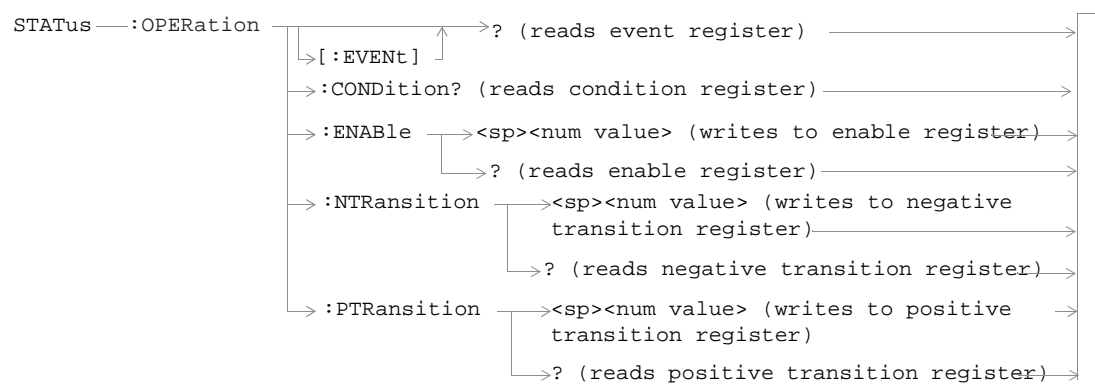

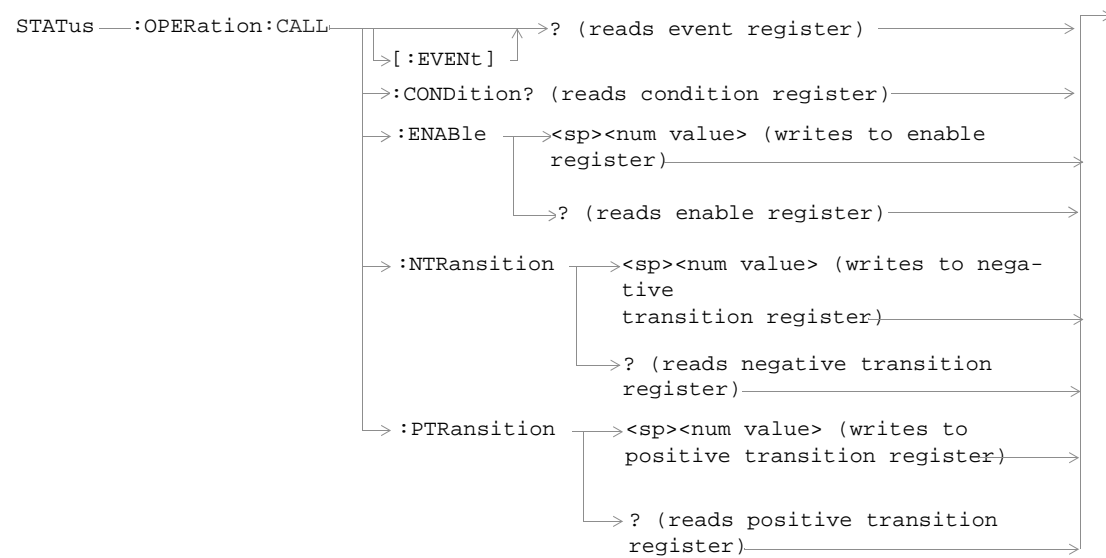

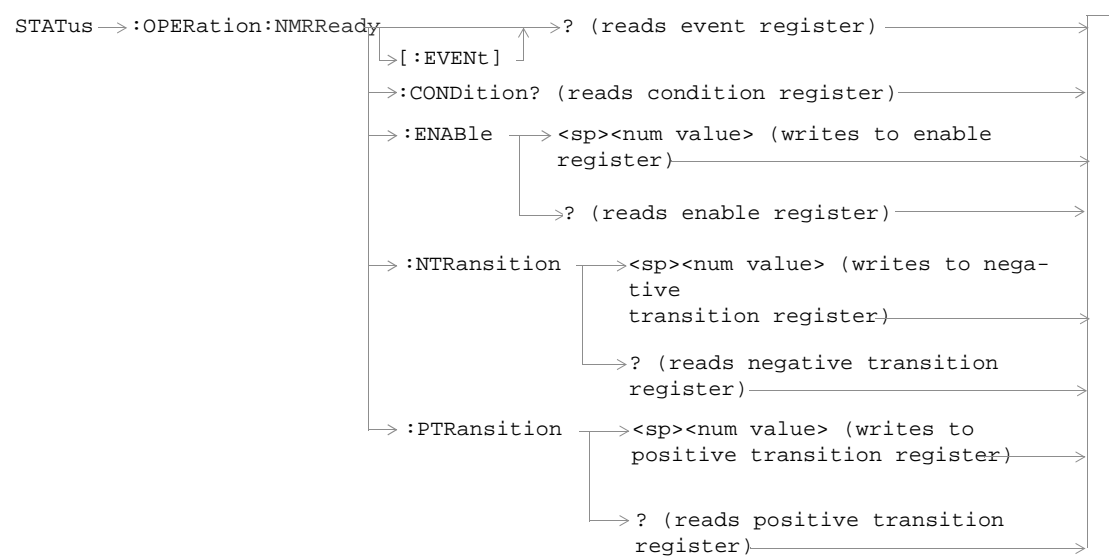

STATus:PRESet

STATus → :PRESet →



STATUS:QUESTIONable

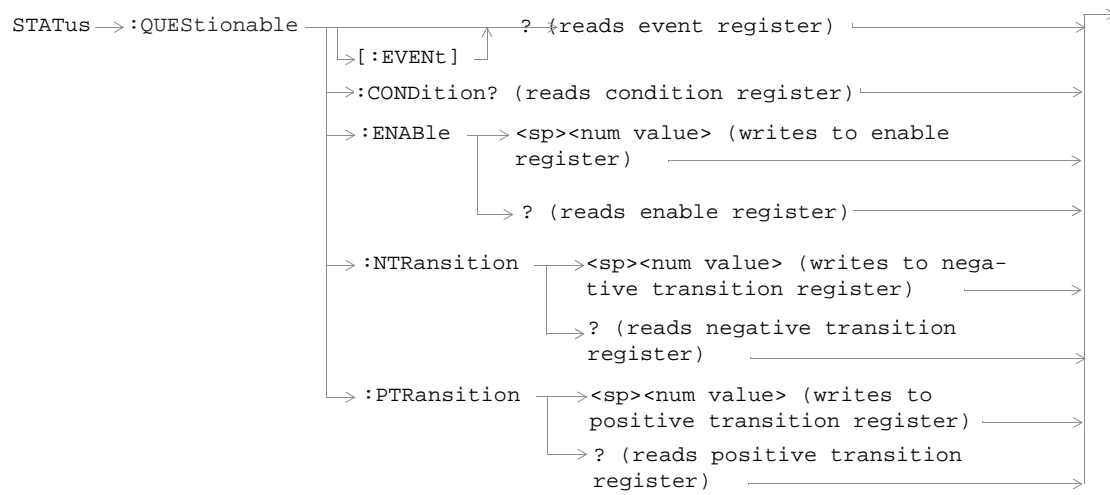

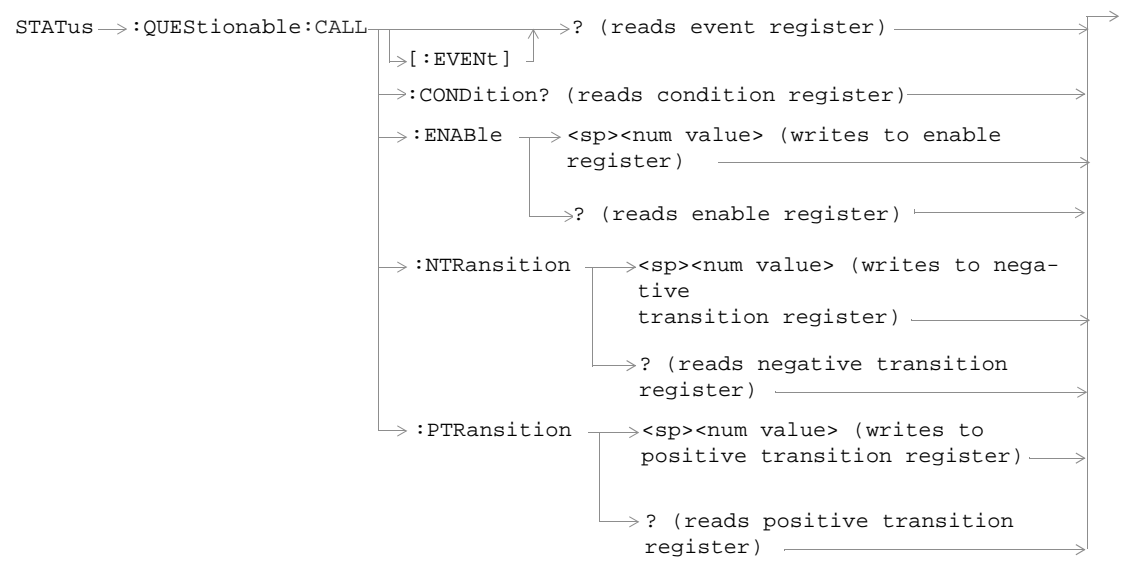

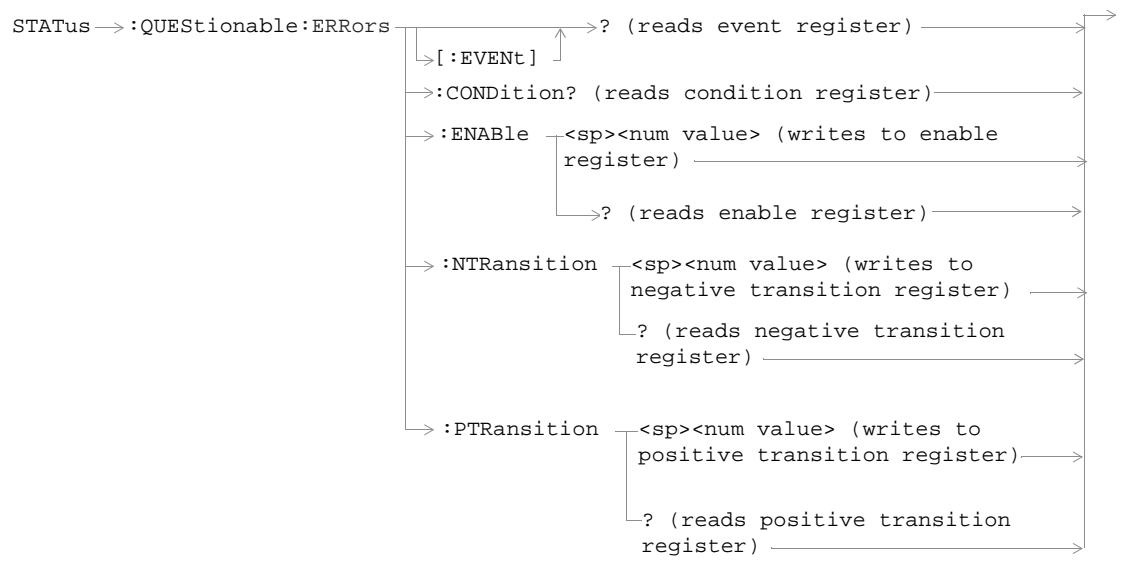

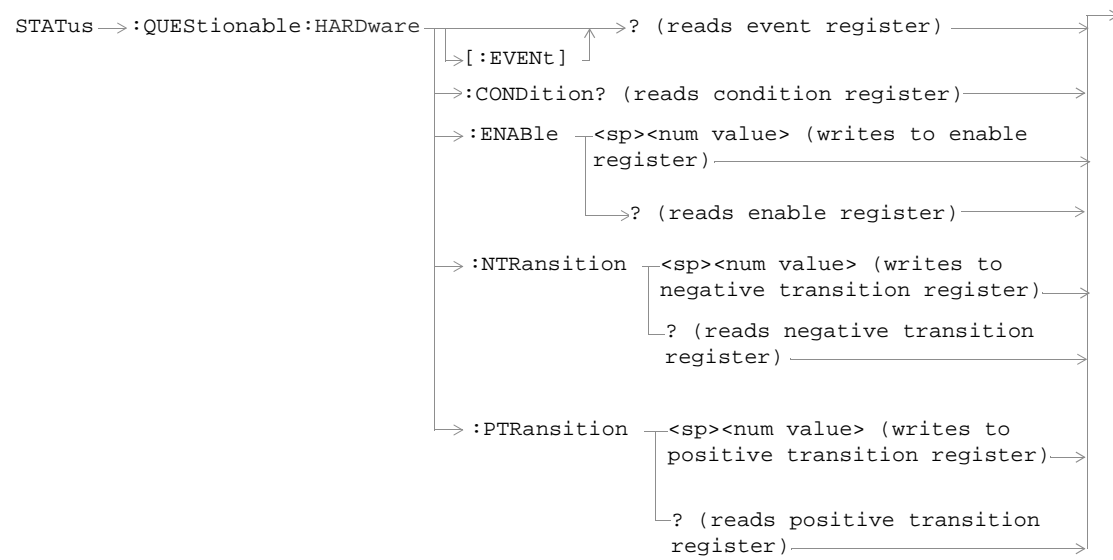

Status Byte Register

*STB?

*STB? 

Standard Event Status Register

*ESR?

*ESR? —————> Reads and clears the Std Event Status Register. ↗

*ESE?

*ESE? —————> Reads the Std Event Status Register Enable Register ↗

*ESE

*ESE —————> Writes to the Std Event Status Register Enable Register ↗

SYSTem:BEEPer

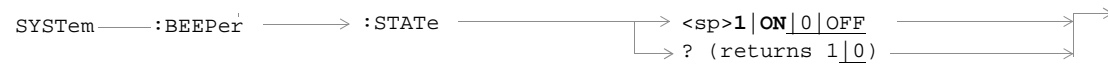

SYSTem:COMMunicate

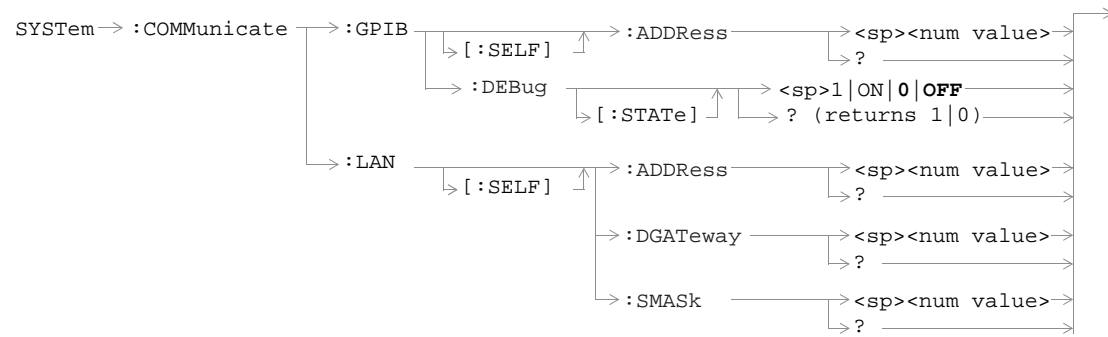

SYSTem:CORRection

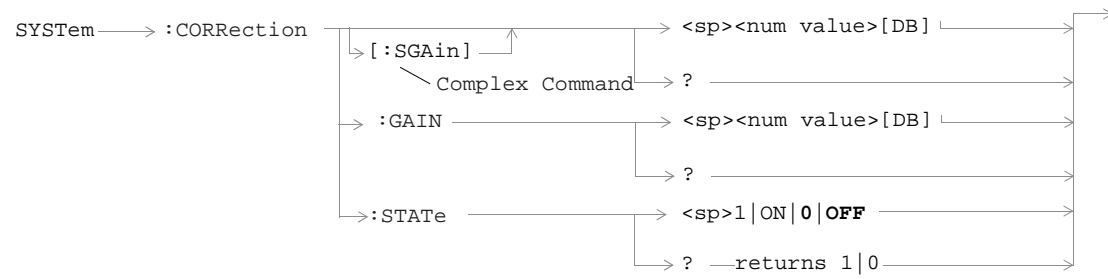

SYSTem:CURRent:TA

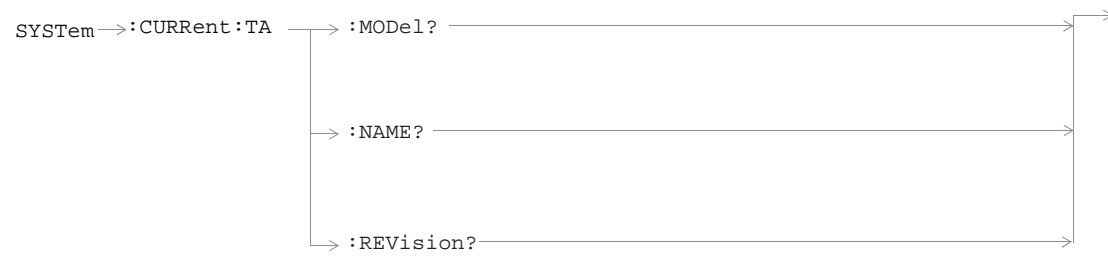

SYSTem:ERRor?

SYSTem → :ERRor? →



SYSTem:FTRigger

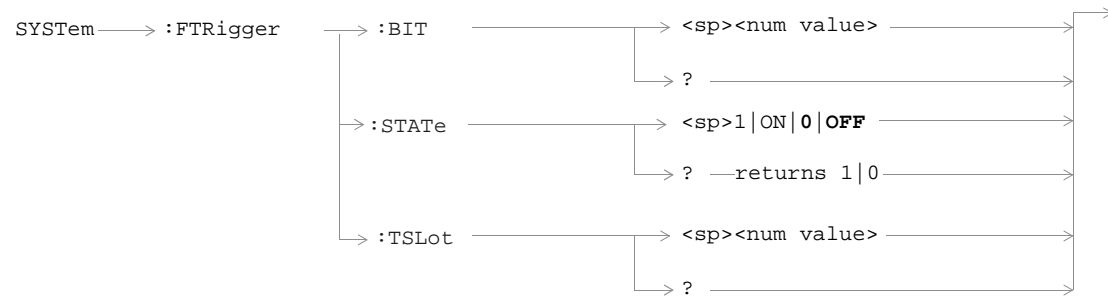

SYSTem:MEASurement

SYSTem → :MEASurement:RESet →

SYSTEM:PRESet

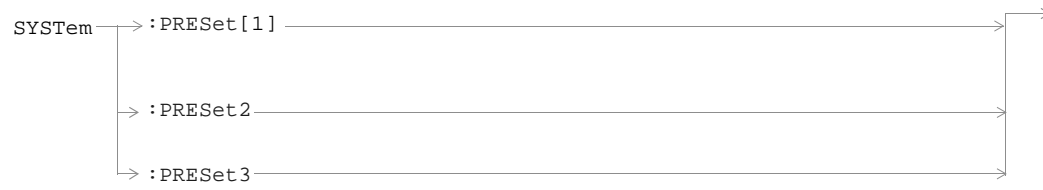

SYSTem:ROSCillator

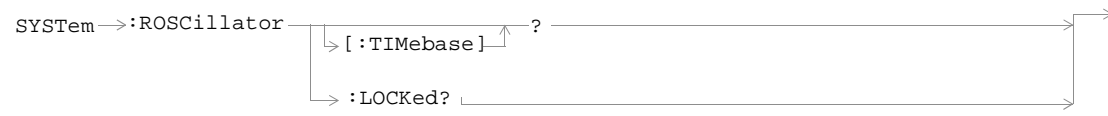

SYSTem:SYNChronized

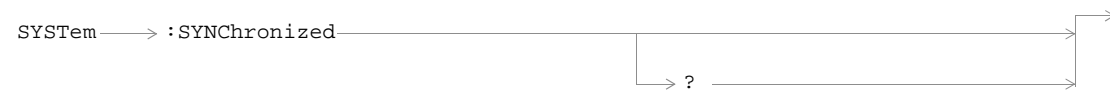

HP-IB IEEE 488.2 Common Commands

"*CLS" on page 103

"*ESE" on page 103

"*ESE?" on page 103

"*ESR?" on page 104

"*IDN?" on page 104

"*OPC" on page 104

"*OPC?" on page 105

"*OPT?" on page 105

"*RST" on page 106

"*SRE" on page 107

"*SRE?" on page 107

"*STB?" on page 108

"*WAI" on page 108

***CLS**

The *CLS, clear status command, is defined in "IEEE Std 488.2-1992", 10.3. This command will also clear and close the error message screen on the test set's display.

***ESE**

The *ESE, standard event status enable command, is defined in "IEEE Std 488.2-1992", 10.10.

***ESE?**

The *ESE?, standard event status enable query, is defined in "IEEE Std 488.2-1992", 10.11.

***ESR?**

The *ESR?, standard event status register query, is defined in "IEEE Std 488.2-1992 ",10.12.

***IDN?**

The *IDN?, identification query is defined in "IEEE Std 488.2-1992", 10.14. *IDN? is used to retrieve information about the test set in ASCII format.

*IDN?, returns ASCII codes 32 through 126 excluding comma and semicolon in four comma separated fields. Field 1 returns the manufacturer, field 2 returns the instrument model number, field 3 returns the serial number, field 4 returns 0.

For revision information on the currently installed test application, see "SYSTem:CURRent:TA" on page 95.

***OPC**

The *OPC, operation complete command, is defined in "IEEE 488.2-1992", 10.18. *OPC causes the test set to continuously sense the No Operation Pending flag. When the No Operation Pending flag becomes TRUE, the OPC event bit in the standard event status register (ESR) is set to indicate that the state of all pending operations is completed. The *OPC common command is not recommended.

***OPC?**

The *OPC?, operation complete query, is defined in "IEEE Std 488.2-1992", 10.19. The *OPC? query allows synchronization between the controller and the test set using either the message available (MAV) bit in the status byte, or a read of the output OPC?. The *OPC? query does not effect the OPC event bit in the Standard Event Status Register (ESR). The *OPC? common command is not recommended.

***OPT?**

The *OPT?, option identification query, is defined in "IEEE Std 488.2-1992", 10.20. Each option will have a unique name, that name will be returned with the query.

***RST**

The *RST command is defined in "IEEE Std 488.2-1992", 10.32. The *RST command is a full preset, which restores a majority of settings to their default values.

Affects of Sending the *RST Command

- All pending operations are aborted.
- Measurement triggering is set to single.
- Any previously received operation complete command (*OPC) is cleared.
- Any previously received operation complete query (*OPC?) is cleared.
- The power-up self-test diagnostics are not performed.
- The contents of the save/recall registers are not affected.
- Calibration data is not affected.
- The HP-IB interface is not reset (any pending service request is not cleared).
- All enable registers are unaffected: service request, standard event, communicate, hardware #1, hardware #2, operation, calibration, and questionable data/signal.
- All negative transition filter registers are unaffected: communicate, hardware #1, hardware #2, operation, calibration, and questionable data/signal.
- All positive transition filter registers are unaffected: communicate, hardware #1, hardware #2, operation, calibration, and questionable data/signal.

- The contents of the RAM memory are unaffected.
- The contents of the output queue are unaffected.
- The contents of the error queue are unaffected.

***SRE**

The *SRE, service request enable command, is defined in “IEEE Std 488.2-1992”, 10.34. The parameter range for this command is 0 through 255.

***SRE?**

The *SRE?, service request enable query, is defined in “IEEE Std 488.2-1992”, 10.35. Values returned by this query range from 0 through 255.

***STB?**

The *STB?, read status byte query, is defined in “IEEE Std 488.2-1992”, 10.36. Values returned by this query range from 0 through 255.

***WAI**

The *WAI, wait-to-continue command, is defined in “IEEE Std 488.2-1992”, 10.39. The *WAI command prevents the test set from executing any further commands or queries until all pending operation flags are false. The *WAI common command is not recommended.

Syntax Equivalents

To find a syntax equivalent for a field on the Test Set's display.

1. Find the field name on the Test Set's display.

2. Look up the name in the alphabetical listing.

3. Turn to the page indicated.

Numerics

3 Digit MNC for PCS 1900, 34

A

Active Cell Status, 39
Amplitude, 11
Amplitude Offset, 94
Analog Audio Setup, 63

B

BA Table, 14
Band Pass Filter Frequency
 AAUD, 63
 DAUD, 68
BCC (Base Station Colour Code), 16
Beeper State, 92
Bit Error Setup, 65

Broadcast Chan, 17
Burst Synchronization
 PFER, 76
Burst Synchronization
 PVT, 78
Burst Timing Error, 39

C

Cal. first IQ mod, 12
Cal. second IQ mod, 12
Cell Activated State, 13
Cell Band, 15
Cell Power, 35
Cell Power State, 35
Corrupted Bursts, 20

D

Decode Errors, 20
Decoded Audio Setup, 68
Display mode, 44

E

End Call, 21
Expected Audio Amplitude, 63
Expected Burst, 18
Expected Peak Audio Amplitude, 63
Expected Power, 61
External trigger Bit Position, 97
External trigger state, 97

External trigger Timeslot, 97

F

FBER Setup, 70
Frequency, 11

G

Get IMEI at Call Setup, 23

H

HP-IB Address, 93

L

LAC (Location Area Code), 24
LAN IP Address, 93

M

Manual Band, 61
Manual Channel, 61
Manual Frequency, 61
Max Frames Allowed for Assignment, 20
MCC (Mobile Country Code), 25
Measurement Log, 96
Measurement Offsets
 PVT, 78
Measurement Timeout
 AAUD, 63
 BERR, 65

Syntax Equivalents

- DAUD, 68
 - FBER, 70
 - ORFS, 75
 - PFER, 76
 - PVT, 79
 - TXP, 80
 - Measurement Type, 65
 - Measurement Unit, 48, 49
 - Missing Bursts, 20
 - MNC (Mobile Network Code), 26
 - Mobile Loopback, 42
 - Modulation Offset
 - ORFS, 72
 - Modulation Offset #
 - ORFS, 72
 - Multi-Measurement Count
 - ORFS, 72
 - PFER, 76
 - PVT, 78
 - TXP, 80
 - Multi-Measurement Count (Modulation)
 - ORFS, 72
 - Multi-Measurement Count (Switching)
 - ORFS, 73
 - Multi-measurement Count Decoded Audio, 68
- N**
- NCC (Network Colour Code), 30
 - Number of bits to test
- BERR, 65**
FBER, 70
- O**
- Operating Mode, 31
 - ORFS Setup, 72
 - Originate Call, 32
- P**
- Pages, 20
 - Paging IMSI, 33
 - Phase & Freq Setup, 76
 - Power vs Time Measurement Setup, 78
 - Pulse, 11
- R**
- RACHs, 20
 - Receiver Control, 61
 - Repeat Paging, 33
- S**
- Speech, 42
 - Speech Frames Delay, 65
 - Switching Offset
 - ORFS, 73
- T**
- TDMA Frames Delay, 70
- U**
- Test Function, 22
 - Time Offset
 - PVT, 78
 - Timeslot, 42
 - Traffic Band, 41
 - Traffic Channel, 40
 - Trigger Arm
 - AAUD, 63
 - BERR, 65
 - DAUD, 68
 - FBER, 70
 - ORFS, 72
 - PFER, 76
 - PVT, 78
 - TXP, 80
 - Trigger Delay
 - ORFS, 75
 - TXP, 81
 - Trigger Qualifier
 - PFER, 77
 - TXP, 81
 - Trigger Source
 - ORFS, 75
 - PFER, 77
 - PVT, 79
 - TXP, 81
 - TX Power Setup, 80
- Use 3 Digit MNC for PCS 1900, 34**
-